

TM 11-6625-539-15-2

DEPARTMENT OF THE ARMY TECHNICAL MANUAL

OPERATOR, ORGANIZATIONAL DS, GS,
AND DEPOT MAINTENANCE MANUAL

TEST SET,
TRANSISTOR TS-1836B/U

This copy is a reprint which includes current pages from Changes 1 through 3. Title was changed by Change 3.

HEADQUARTERS, DEPARTMENT OF THE ARMY

04 OCTOBER 1968

TECHNICAL MANUAL }
 No. 11-6625-539-15-2 }

HEADQUARTERS
 DEPARTMENT OF THE ARMY
 WASHINGTON, D.C., 4 October 1968

OPERATOR, ORGANIZATIONAL DIRECT SUPPORT, GENERAL SUPPORT,
 AND DEPOT MAINTENANCE MANUAL
 INCLUDING REPAIR PARTS AND SPECIAL TOOL LISTS

TEST SET, TRANSISTOR TS-1836B/U

	Paragraph	Page
CHAPTER 1.	INTRODUCTION	
Section I.	General	
	Scope	1-1 1-1
	Indexes of publications	1-2 1-1
	Forms and records	1-3 1-1
	Reporting of errors	1-3.1 1-1
	Reporting equipment improvement recommendations	1-3.2 1-1
	Administrative storage	1-3.3 1-1
	Destruction of Army electronics materiel	1-3.4 1-1
II.	Description and data	
	Description and use	1-4 1-1
	Technical characteristics	1-5 1-2
	Items comprising an operable Test Set, Transistor TS-1836B/U	1-6 1-3
CHAPTER 2.	INSTALLATION	
	Unpacking	2-1 2-1
	Checking unpacked equipment	2-2 2-1
	Cable connections	2-3 2-1
3.	OPERATING INSTRUCTIONS	
	General	3-1 3-1
	Preliminary operating instructions	3-2 3-1
	Controls and indicators	3-3 3-1
	Operating	3-4 3-1
	Methods for servicing semiconductors circuitry	3-5 3-4
	Determining types of failures	3-6 3-4
4.	OPERATOR'S AND ORGANIZATIONAL MAINTENANCE	
	Scope of maintenance	4-1 4-1
	Preventive maintenance	4-2 4-1
	Preventive maintenance checks and services periods	4-3 4-1
	Operator's daily preventive maintenance checks and services chart	4-4 4-2
	Operator's weekly preventive maintenance checks and services chart	4-5 4-2
	Organizational monthly preventive maintenance checks and services chart	4-6 4-2
	Cleaning	4-7 4-2
	Rustproofing and painting	4-8 4-2
5.	CIRCUIT FUNCTIONING	
	Introduction	5-1 5-1
	Battery	5-2 5-1
	Beta and diode in-circuit checks	5-3 5-1
	OHMS E-B, C-B, and C-E resistance checks	5-4 5-2
	Leakage ICO X1 and X10 check	5-5 5-2
	DIODE 1-10 ratio check	5-6 5-2
	F.E.T. CAL check	5-7 5-3
	F.E.T. READ check	5-8 5-4
6.	TROUBLESHOOTING AND REPAIR	
	Troubleshooting techniques	6-1 6-1
	Troubleshooting chart	6-2 6-2
7.	ALIGNMENT PROCEDURES	
	General	7-1 7-1
	Alignment of meter zero	7-2 7-1
	Alignment of meter OHMS position	7-3 7-1
	Alignment of meter F.E.T. position	7-4 7-2

	Paragraph	Page
CHAPTER 8.	GENERAL SUPPORT TESTING PROCEDURES	
	General	8-1 8-1
	Test equipment and material	8-2 8-1
	Modification work orders	8-3 8-1
	Physical tests and inspection	8-4 8-1
	Meter OHMS position test	8-5 8-2
	Test set F.E.T. position test	8-6 8-2
9.	DEPOT OVERHAUL STANDARDS	
	Applicability of depot overhaul standards	9-1 9-1
	Applicable references	9-2 9-1
	Test facilities required	9-3 9-1
	Depot overhaul standards tests.	9-4 9-1
10.	SHIPMENT AND LIMITED STORAGE AND DEMOLITION TO PREVENT ENEMY USE	
Section I.	Shipment and limited storage	
	Disassembly of equipment	10-1 10-1
	Repackaging for shipment or limited storage	10-2 10-1
II.	Demolition of materiel to prevent enemy use	
	Authority for demolition	10-3 10-1
	Methods of destruction	10-4 10-2
APPENDIX A.	REFERENCES	
B.	BASIC ISSUE ITEMS LIST (BIIL) AND ITEMS TROOP INSTALLED OR AuTHORIZED LIST (ITIAL) (Not Applicable)	
C.	MAINTENANCE ALLOCATION	
Section I.	Introduction	
II.	Maintenance allocation chart.	
APPENDIX D.	DELETED	
E.	TRANSISTOR CHARACTERISTICS DATA FOR TEST SET, TRANSISTOR TS-183613/U.	

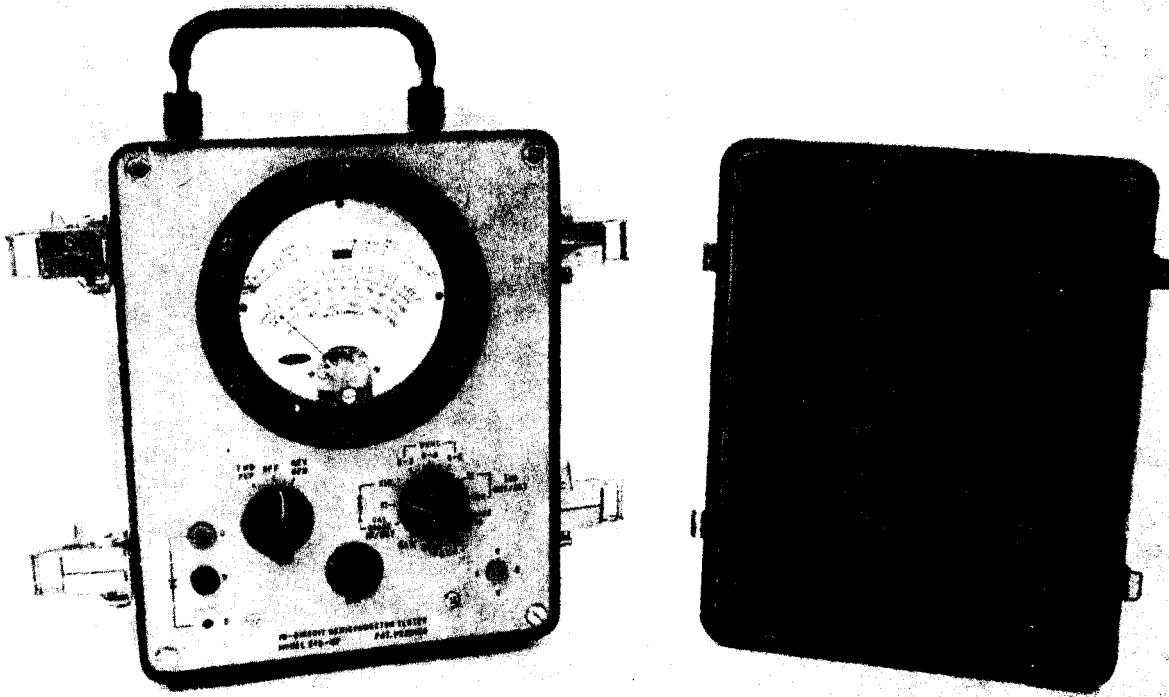

TM6625-539-15-2-1

Figure 1-1. Test set, Transistor TS-1836B/U.

1-6. Items Comprising an Operable Test Set, Transistor TS-1836B/U

<i>FSC</i>	<i>QTY</i>	<i>Manufacturer, part No., and other code</i>
		NOTE
		The part number is followed by the applicable 5-digit Federal supply code for manufacturers (FSCM) identified in SB 706-42 and used to identify manufacturer, distributor, or Government agency, etc.
		NOTE
		Dry batteries shown are used with the equipment but are not considered part of the equipment. They will not be preshipped automatically but are to be requisitioned in quantities necessary for the particular organization in accordance with SB 11-6.
6625-813-9205	1	Test Set, Transistor TS-1836B/U
		which includes:
6625-813-9205	1	Cover, Test Set 4252193-503, 24624
6135-120-1010		Battery, Dry BA-42
	1	Lead, Test 22801905, 93346
	1	Lead, Test 2280190-6, 93346
	1	Lead, Test 2280190-7, 93346

CHAPTER 2

INSTALLATION

2-1. Unpacking

a. Packaging Data. When packed for shipment, Test Set, Transistor TS-1836B/U is placed in a waterproof carton and packed in a wooden packing case. A typical packing case and its contents are shown in figure 2-1.

b. Removing Contents (Wooden Packing Case). Perform all the procedures in (1) through (5) below when unpacking equipment packed in a wooden packing case (fig. 2-1).

- (1) Cut and fold back the metal straps.

Caution: Do not attempt to pry off the sides; this may damage the equipment.

- (2) Remove the nails from the cover and one side of the wooden packing case with a nailpuller. Remove the cover and one side.

- (3) Open the moistureproof barrier that covers the outer corrugated carton. Remove the carton.

- (4) Open the outer corrugated carton and the moisture-vaporproof barrier within the carton. Remove the inner corrugated carton.

- (5) Open the inner corrugated carton, and remove the instrument.

2-2. Checking Unpacked Equipment

a. Inspect the equipment for damage incurred during shipment.

b. Check to see that the equipment is complete. The equipment is normally shipped less the batteries. Report all discrepancies in accordance with TM 38-750. Shortage of a minor assembly or part that does not affect proper functioning of the equipment should not prevent use of the equipment.

c. If the equipment has been used or reconditioned, see whether it has been changed by a modification work order (MWO). If the equipment has been modified, the MWO number will appear on the side near the nomenclature plate. Check to see whether the MWO number (if any) and appropriate notations concerning the modification have been entered in the equipment manual.

Note. Current MWO's applicable to the equipment are listed in DA Pam 310-7.

2-3. Cable Connections

No cable connections are necessary for operation of the test set other than the three accessory test leads. Connect the three accessory test leads as follows:

- a.* Insert the red plug into the red jack.
- b.* Insert the black plug into the black jack.
- c.* Insert the yellow plug into the yellow jack.

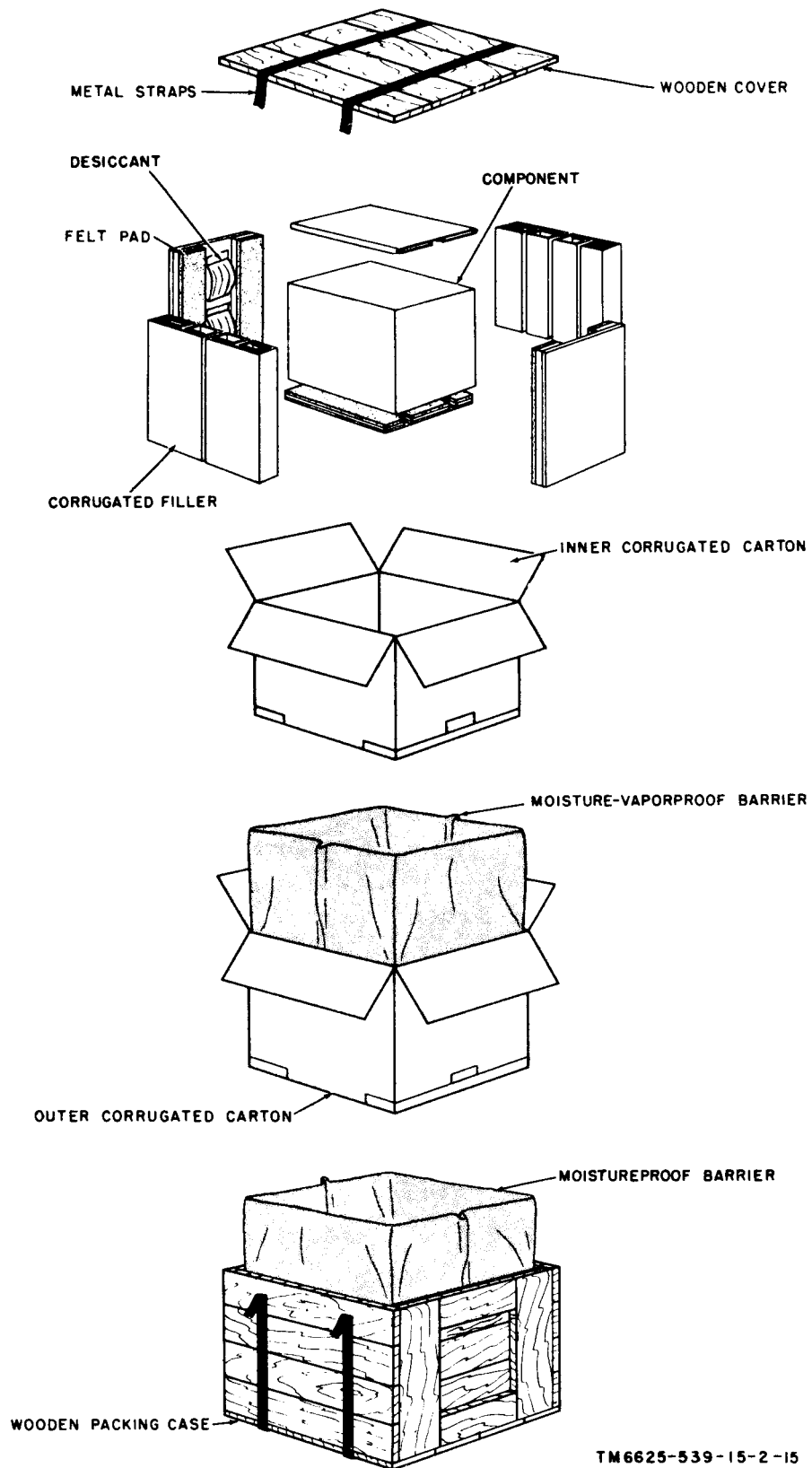

TM6625-539-15-2-15

Figure 2-1. Typical packaging diagram.

CHAPTER 3

OPERATING INSTRUCTIONS

3-1. General

The test set is designed so that it is a safe instrument to use with semiconductor circuitry. The voltage and current levels that the test set can supply to any device are controlled so that the accidental misplacing of leads will not damage any semiconductor; however, to achieve valid readings, proper operation and switch setting are required. Controls and indicators, with the function of each, are listed in paragraph 3-3. Operating procedures are described in paragraph 3-4.

3-2. Preliminary Operating Instructions

Before operating the test set, check the meter to be sure that the pointer indicates exactly 0. If it does not, turn the adjusting screw on the front of the meter until the pointer is zeroed. The polarity switch should be set to OFF.

3-3. Controls and Indicators

The controls for the test set are on the front panel; their functions are described in the chart below.

<i>Control or Indicator</i>	<i>Function</i>
Polarity switch -----	When rotated to any position other than OFF, selects proper voltage and current polarities for type of semiconductor device being tested and for making reverse to forward ratio diode tests.
Function switch -----	Selects desired function to be tested.
CAL control-----	a. When beta is being measured, sets collector current of transistor under test to 1 ma. b. When field effect transistors are being measured, sets gate to source voltage at 100 mv. c. When forward ratio test is being made, sets diode current to 1 milliampere.
Color-coded jacks-----	Used in conjunction with color-coded plug-in cables to make connection from test set to semiconductor under test.

<i>Control of indicator</i>	<i>Function</i>
Meter -----	Provides readings in beta ohms, I_{co} in microamperes, and G_u in micromhos as required to test semiconductor devices and BAT range to check condition of internal batteries.
Transistor socket ----	For use in conjunction with short lead out-of-circuit transistors. Transistors may be plugged into socket directly.

3-4. Operating Procedures

a. *General.* Before operating the test set, check the meter to see if the pointer falls on the meter 0. If it does not, turn the meter adjust screw, either clockwise or counterclockwise, until the pointer is exactly over the 0 mark on the left side of the meter scale. The meter is shipped with the polarity switch placed in the OFF position. When the polarity switch is set to OFF, all of the batteries of the tester are disconnected from the circuitry and a short circuit is placed across the meter. The polarity switch should be set to OFF when the instrument is not being used.

Caution: Never leave the polarity switch of the instrument in one of the test positions when the instrument is not being used. Always return the polarity switch to the OFF position to prevent unnecessary drain of the internal batteries.

b. Beta Measurement (Out-of-Circuit).

(1) If a transistor with short leads is being measured, place the transistor in the small socket on the lower right side of the front panel. The transistor jacks on the front panel are spaced so that they will accept a standard test adapter for rapid testing of transistors with long leads.

(2) Plate the polarity switch to correspond to the type of semiconductor device being used.

(3) Set the function switch to BETA CAL, and adjust the CAL control for full-scale meter deflection.

(4) Place the function switch to the BETA X1 range, and read the BETA directly on the top (BETA) scale of the meter. If the BETA is on the high portion of the BETA scale, advance the function switch to the BETA X10 range and multiply the reading by 10.

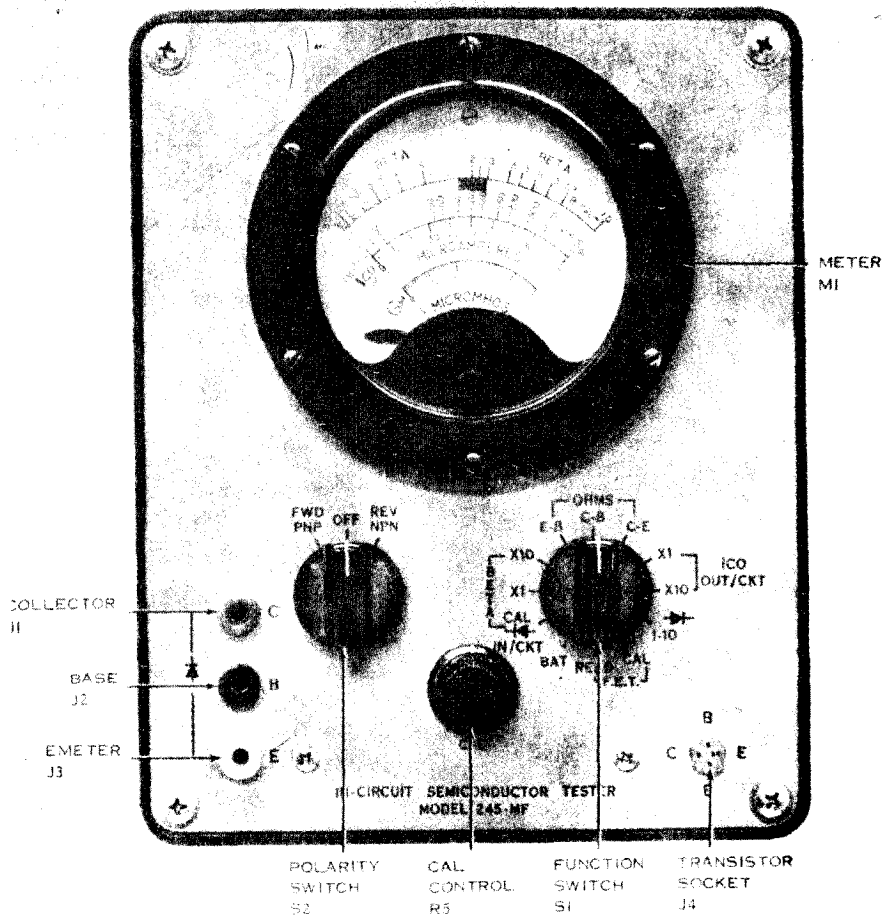

TM 11-6625-539-15-2-3

Figure 3-1. Test Set, Transistor TS-1836B/U, controls and indicators.

c. Beta Measurement (In Circuit).

(1) Insert the three test leads supplied with the instrument into the three color-coded jacks on the front panel, being careful to insert the red probe into the red jack, the black probe into the black jack, and the yellow probe into the yellow jack. Connect the other ends of the test leads to the transistor under test. Be careful to connect the red-coded alligator clip to the collector, the black-coded alligator clip to the base, and the yellow-coded alligator clip to the emitter.

(2) Set the polarity switch to correspond to the type of device being tested.

(3) Set the function switch to the BETA CAL position, and adjust the CAL control for full-scale meter deflection.

(4) Advance the function switch to the BETA X1 range, and read the BETA directly on the top

(BETA) scale of the meter. If the BETA falls in the high portion of the BETA scale, advance the function switch to the BETA X10 range and multiply the BETA reading by 10.

d. Electrode Resistance Measurement (In- or Out-of-Circuit).

(1) Connect the leads to the transistor under test, as described in *b(1)* above for out-of-circuit measurement, as described in *c(1)* above for in-circuit measurement.

(2) Place the polarity switch to correspond to the type of semiconductor device being tested.

(3) Set the function switch to OHMS E-B.

(4) Read the resistance of the emitter-to-base circuitry directly on the center (OHMS) scale.

(5) Set the function switch to OHMS C-B.

(6) Read the resistance of the collector-to-base circuitry directly on the center (OHMS) scale.

(7) Set the function switch to OHMS C-E.

(8) Read the resistance of the collector-to-emitter circuitry directly on the center (OHMS) scale.

e. I_{co} (Out-of-Circuit).

(1) Set the polarity switch to correspond to the type of semiconductor device being tested.

(2) Place the transistor in the socket on the lower right corner of the front panel.

(3) Set the function switch to ICO OUT/CKT X1.

(4) Read the I_{co} directly in microamperes on the center (ICO) scale.

(5) If the meter indicates in the high portion of the scale, place the function switch in the ICO OUT/CKT X10 position.

(6) Multiply the I_{co} reading in microampere by 10 to obtain the True I_{co} reading.

f. Diodes in Circuit.

(1) Set the polarity switch to FWD PNP.

(2) Connect the cathode of the diode to the red lead of test the cable; connect the anode of the diode to the yellow lead.

(3) Set the function switch to CAL DIODE IN/CKT.

(4) Increase the CAL control until an upward deflection is visible on the meter. If an upward deflection is obtained on the meter, the diode is neither open nor shorted. If there is no deflection, the diode is either open or shorted or the circuit impedance is under 20 ohms.

g. Diodes I_r (Out-of-Circuit).

(1) Set the polarity switch to FWD PNP.

(2) Connect the cathode of the diode to the red lead of the test cable; connect the anode of the diode to the black lead.

(3) Set the function switch to ICO OUT/CKT X1.

(4) Read the I_r directly in microampere on the middle (ICO) scale.

(5) If the meter pointer swings off scale, place the function switch in the ICO OUT/CKT X10 range.

(6) Multiply the I_r reading in microampere by 10 to obtain the true I_r reading.

h. Diodes, Reverse-to-Forward Ratio (Out-of-Circuit).

(1) Set the polarity switch to FWD PNP.

(2) Connect the cathode of the diode to the red lead of the test cable; connect the anode of the diode to the yellow lead.

(3) Set the function switch to DIODE 1-10, and adjust the CAL control for full scale meter deflection.

(4) Set the polarity switch to REV NPN, and read the diode ratio (with a reference to 1) directly on the BETA (top) scale.

i. Field Effect Transistors G_m (Out-of Circuit).

(1) If a field effect transistor with short leads is being measured, place the transistor in the small socket on the lower right side of the front panel. Place the drain lead in pin C, the gate lead in pin B and the source lead in pin E. The transistor jacks on the front panel are spaced so that they will accept a standard test adapter for rapid testing of transistors with long leads.

(2) Set the polarity switch to FWD PNP when testing an N-type transistor, and to REV PNP when testing a P-type transistor.

(3) Set the function switch to F.E.T. CAL, and adjust the CAL control for full-scale meter deflection.

(4) Set the function switch to F.E.T. READ, and read the G_m of the transistor under test directly on the meter on the bottom (G_m) scale.

j. Fields Effect Transistors G_m (In-Circuit).

(1) Insert the three test leads supplied with the instrument into the three color-coded jacks on the front panel, being careful to insert the red probe into the red jack, the black probe into the black jack, and the yellow probe into the yellow jack. Connect the other ends of the test leads to the transistor under test. Be careful to connect the red-coded alligator clip to the drain lead, the black-coded alligator clip to the gate lead, and the yellow-coded alligator clip to the source lead of the field effect transistor.

(2) Set the polarity switch to FWD PNP when testing an N-type transistor, and set it to REV NPN when testing a P-type transistor.

(3) Set the function switch to F.E.T. CAL and adjust the CAL control for full-scale meter deflection.

(4) Set the function switch to F.E.T. READ, and read the G_m of the transistor under test directly on the meter on the bottom (G_m) scale.

k. Battery Check.

(1) Set the function switch to BAT.

(2) The meter pointer should fall in the red box on the top scale labeled BAT. If the meter pointer falls outside this box, the batteries should be replaced.

3-5. Methods for Servicing Semiconductor Circuitry

Test Set, Transistor TS-1836B/U is designed so that it is a safe instrument to use with semiconductor circuitry. The voltage and current levels that the instrument can supply to the device are controlled so that the accidental misplacing of leads will not damage any semiconductor device; therefore, any device failure would be caused by equipment operation and not the manner which the test set is used.

a. Transistors.

<i>Type of failure</i>	<i>Beta</i>	<i>Ohms (E-B, C-B, C-E)</i>
Open emitter-to-base junction _ _ _ _	Beta reads infinity _ _ _	Emitter-to-base ohms test. Meter indicates infinity or emitter-to-base load.
Shorted emitter-to-base junction ___	Test set cannot be set for BETA CAL.	Emitter-to-base ohms test. Meter indicates 0 ohm.
High leakage between the emitter-to-base junction.	Test set cannot be set for BETA CAL.	Emitter-to-base ohms test. Meter indicates low resistance.
Open collector-to-base junction ____	Test set cannot be set for BETA CAL.	Collector-to-base ohms test. Meter indicates infinity or collector-to-base load.
Shorted collector-to-base junction ___	Test set cannot be set for BETA CAL.	Collector-to-base ohms test. Meter indicates 0 ohm.
High leakage between the collector-to-base junction.	Test set cannot be set for BETA CAL.	Collector-to-base ohms test. Meter indicates low resistance.
Open collector-to-emitter _ _ _ _ _ _ _ _	Test set cannot be set for BETA CAL.	Collector-to-emitter ohms test. Meter indicates infinity or the collector-to-emitter load.
Shorted collector-to-emitter_____	Test set cannot be set for BETA CAL.	Collector-to-emitter ohms test. Meter indicates 0 ohm.
High leakage between the collector-to-emitter.	Test set gives reverse indication for BETA CAL.	Collector-to-emitter ohms test. Meter indicates low resistance.

b. Diodes.

<i>Type of failure</i>	<i>Meter indication</i>	
	<i>In-circuit diode measurement</i>	<i>Ohm (C-E)</i>
Shorted diode_ _ _	0 meter deflection _ _ _	0.
Open diode _ _ _ _	0 meter deflection _ _ _	Infinite or circuit resistance.

3-6 Determining Types of Failures

The test set can be used to determine the type of failure encountered, and some of the tests can be used to verify the findings of other tests. The chart in paragraph 2-7 lists the types of failures that can be found and the manner in which the test set can be used to determine the type of failure. An open and a shorted diode both give zero meter deflection on the in-circuit diode measurement test. If the diode is shorted, switching the meter to the C-E OHMS test will give a 0-ohm reading. If the C-E ohms tests shows a resistance or an infinity reading on the meter, the diode is open.

CHAPTER 4

OPERATOR'S AND ORGANIZATIONAL MAINTENANCE

4-1. Scope of Maintenance

a. The maintenance duties assigned to the operator of the test set are listed below, together with a reference to the paragraphs covering the specific maintenance functions. The duties assigned do not require tools or test equipment other than those issued with the equipment.

(1) Operator's daily preventive maintenance checks and services (para 4-4).

(2) Operator's weekly preventive maintenance checks and services (para 4-5).

(3) Cleaning (para 4-7).

b. The maintenance duties assigned to the organizational maintenance repairman of the test set are listed below, together with a reference to the paragraphs covering the specific functions. The duties assigned do not require tools or test equipment other than those issued with the equipment.

(1) Organizational monthly preventive maintenance checks and services (para 4-6).

(2) Rustproofing and painting (para 4-8).

4-2. Preventive Maintenance

Preventive maintenance is the systematic care, servicing and inspection of the equipment to prevent the occurrence of trouble, to reduce downtime, and to assure that the equipment is serviceable.

a. *Systematic Care.* The procedures given in paragraphs 4-4, 4-5, and 4-7 cover routine systematic care and cleaning essential to proper upkeep and operation of the equipment.

b. *Preventive Maintenance Checks and Services.* The operator's preventive maintenance checks and services charts (paras 4-4 and 4-5) outline functions to be performed at specific intervals. These checks and services are designed to maintain Army equipment in a combat-serviceable condition; that is, in good general (physical) condition and in good operating condition. To assist operators in maintaining combat serviceability, the charts indicate what to

check, how to check, and what the normal conditions are; the *References* column lists the paragraphs or manuals that contain detailed repair or replacement procedures. If the defect cannot be remedied by the operator, higher category of maintenance or repair is required. Records and reports of these checks and services must be made in accordance with TM 38-750.

4-3. Preventive Maintenance Checks and Services Periods

Preventive maintenance checks and services of the TS-1836B/U are required daily, weekly, and monthly.

a. Paragraph 4-4 specifies the checks and services that must be accomplished daily and under the special conditions listed below:

(1) Before the test set is taken on a mission.

(2) When the test set is initially installed.

(3) When the test set is reinstalled after removal for any reason.

(4) At least once a week, if the equipment is maintained in standby condition.

b. Paragraphs 4-5 and 4-7 specify additional checks and services that must be performed on a weekly and monthly basis, respectively. Perform the maintenance functions indicated in the organizational monthly preventive maintenance checks and services chart (para 4-6) once each month. A month is defined as approximately 30 calendar days of 8-hour-per-day operation. If the equipment is operated 16 hours a day, the monthly preventive maintenance checks and services should be performed at 15-day intervals. Adjustment of the maintenance interval must be made to compensate for any unusual operating conditions. Equipment maintained in a standby (ready for immediate operation) condition must have monthly preventive maintenance checks and services. Equipment in limited storage (requires service before operation) does not require monthly maintenance.

4-4. Operator's Daily Preventive Maintenance Checks and Service Chart

Sequence No.	Item to be inspected	Procedure	References
1	Test set	Check equipment for completeness and general condition	App B.
2	Exterior surfaces	Clean exterior surfaces of the equipment	Para 4-7.
3	External receptacles	Inspect external receptacles for breakage and looseness	
4	Meter glass	Inspect front panel glass window for damaged housing, broken glass, physical damage, dust, or moisture.	
5	Knobs, controls, and switches	During operation (sequence No. 6), check knobs, controls, and switches for proper mechanical action. Action must be positive, without backlash, binding, or scraping.	
6	Operation	During operation, be alert for any abnormal indications	

4-5. Operator's Weekly Preventive Maintenance Checks and Services Chart

Sequence No.	Item to be inspected	Procedure	References
1	Cables	Inspect external cables for cuts, cracked or gouged jackets, fraying, or kinks.	
2	Hardware	Inspect all exterior hardware for looseness and damage. The test set cover, carrying handle, latches, and all bolts and screws must be tight and not damaged.	
3	Preservation	Inspect equipment for bare spots, rust, and corrosion. If these conditions exist, refer to a higher maintenance category for repair.	Paras 4-7 and 4-8.
4	Batteries	Inspect batteries for leakage, corrosion, and swelling	

4-6. Organizational Monthly Preventive Maintenance Checks and Services Chart

Sequence No.	Item to be inspected	Procedure	References
1	Publications	Inspect the manual for completeness and usable condition. Be sure that all changes to the manual are on hand.	DA Pam 310-4.
2	Modification work orders	Check to see that all URGENT MWO's have been applied and that all NORMAL MWO's have been scheduled.	DA Pam 310-7.
3	Completeness	Check the equipment for completeness and general condition	App B.
4	Cleanliness	Clean the exterior surfaces of the equipment	Para 4-7.
5	Preservation	Inspect the equipment to determine that it is free of bare spots, rust, and corrosion.	Para 4-8.
6	External receptacles	Inspect the external receptacles for breakage and looseness	
7	Meter glass	Inspect the front panel glass for damaged housing, broken glass, physical damage, dust, or moisture.	
8	Cables	Inspect the external cables for cuts, cracked or damaged jackets, fraying, or kinks.	
9	Operation	During operation, be alert for any abnormal indication	

4-7. Cleaning

Inspect the exterior surface of the test set. The exterior surface should be free of dirt, grease, and fungus.

a. Remove dust and other loose dirt with a clean, Soft cloth.

Warning: Prolonged breathing of cleaning compound is dangerous; make certain that adequate ventilation is provided. Cleaning compound is flammable; do not use near a flame. Avoid contact with the skin; wash off any that spills on your hands.

b. Remove grease, fungus, and ground-in dirt from the cases; use a cloth dampened (not wet) with cleaning compound (FSN 7930-395-9542).

c. Remove dirt from plugs and jacks with a brush.

Caution: Do not press on the meter face (glass) when cleaning; the meter may become damaged.

d. Clean the front panel, meter, and control knobs; use a soft, clean cloth. If necessary, dampen the cloth with water; mild soap may be used for more effective cleaning.

4-8. Rustproofing and Painting

a. *Rustproofing.* When the finish on the test set has become badly scarred or damaged, rust and corrosion can be prevented by touching up the bare spots. Use No. 000 sandpaper to clean the surface down to the bare metal. Obtain a bright, smooth finish.

b. *Painting.* Remove rust and corrosion from mental surfaces by lightly sanding them with fine sandpaper. Brush two thin coats of paint on the bare metal to protect it. Refer to the applicable cleaning and re-finishing practices specified in TB SIG 364.

CHAPTER 5

CIRCUIT FUNCTIONING

5-1. Introduction

Circuits for Test Set, Transistor TS-1836B/U can be divided into four functional loops: Multivibrator, current limiting, audio amplifier, and switching. The multivibrator stage produces an amplified square wave signal that is applied to the switching circuits through coupling transformer T1. The current limiting network is provided for the protection of the semiconductor under test and to limit the current to the transistor when resistance tests are conducted. The audio amplifier is used in conjunction with the F.E.T. test to provide a parallel source to operate the meter. The switching circuit incorporates a 12-position, 9-wafer function and a 3-position, 12-pole 3-wafer type polarity (FND PNP/OFF/REV NPN) switch.

5-2. Battery Check

A simplified schematic diagram of the circuit used to check the batteries in the test set is shown in figure 5-1. With the function switch in the BAT. position, +9 volts is fed through series resistor R32 and meter M1. The resistance of R32 limits the deflection of meter M1 to the BAT position on the scale.

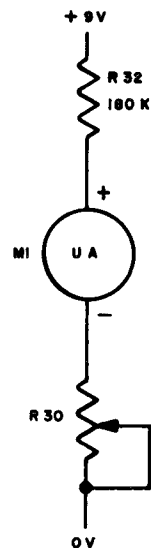

TM6625-539-15-2-4

Figure 5-1. Battery check, simplified schematic diagram.

5-3. Beta and Diode In-Circuit Checks

a. A simplified schematic diagram of the circuit used to calibrate for beta is shown in figure 5-2. Figure 5-2 illustrates a PNP-type transistor; however,

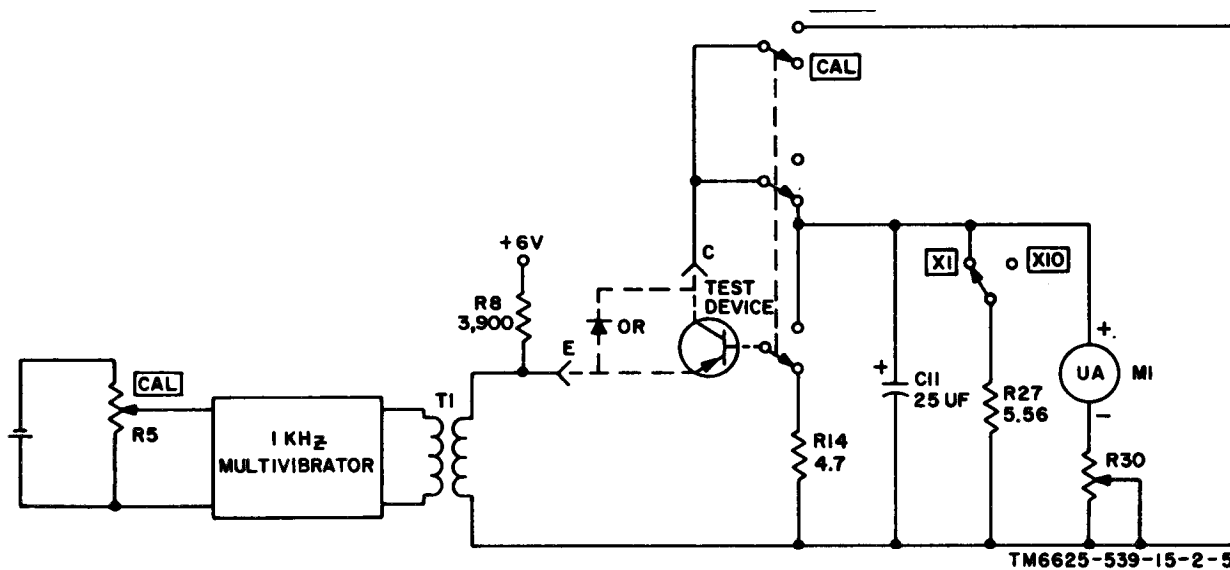

TM6625-539-15-2-5

Figure 5-2. Beta and diode check, simplified schematic diagram.

the same principle applies for NPN and four-element devices (tetrodes) when the fourth lead is left open-circuited.

b. With the switch in the BETA CAL position, 1-kilohertz (kHz) multivibrator Q1, Q2, and Q3 applies a symmetrical square wave to the input of the test device. The magnitude of the square wave is adjustable by CAL resistor R5. The output of the square wave generator is coupled to the test device by transformer T1. With the switch in the BETA CAL position, the amplitude of the square wave is adjusted by CAL resistor R5 until a 1-milliampere (ma) current flows in the collector of the test device. Setting the function switch to BETA X1 connects meter M1 to indicate the base current. Meter M1 is calibrated directly in beta from the relationship $\beta = I_c/I_b$, and beta is read directly. Setting the function switch to BETA X10 removes shunt resistor R27 from the meter, and the meter is 10 times as sensitive as in the BETA X1 position.

5-4. OHMS E-B, C-B, and C-E Resistance Checks

a. Figure 5-3 is a schematic diagram of the circuit used to measure resistance of transistor junctions. Figure 5-3 illustrates the emitter-to-base resistance measurements; however, the same principle applies to collector-to-base, and collector-to-emitter resistance measurements.

b. Resistor R10 and 6.8-volt Zener diode VR1 serve as a voltage divider. The Zener diode establishes con-

stant voltage source, eliminating the need for a meter zero potentiometer. Resistors R11 and R12 limit the maximum current through the meter to 100 ma. Resistor R11 is variable to compensate for tolerance variations of the meter and resistor R13, which is in series with the meter. Without the test device in the circuit, the full 100 ma flows through the meter, causing full scale deflection, which corresponds to a reading of infinity. With the test device in the circuit, current flow through the test device, which is inversely proportional to resistance, results in a decrease in current flow through the meter. Meter deflection in some amount less than full scale, depending on the resistance of the test device, and indicates, directly in ohms, the resistance of the element under test. Because the test set measures semiconductor resistance at very low current and voltage levels, resistance at the semiconductor electrodes may be measured without polarizing the leads. The voltage used, 0.01 volt, is well below the knee of a voltage-current diode plot; consequently, the resistance of the diode is extremely high. The correct value of resistance is read unless the diode is short-circuited or is excessively leaky.

5-5. Leakage ICO X1 and X10 Check

A simplified schematic diagram of the circuit used to check I_{co} (direct current (dc) collector current when the collector junction is reverse-biased and the emitter is open-circuited) is illustrated in figure 5-4. Figure 5-4 illustrates a PNP transistor. With the function switch in the ICO X1 position, the test device is reverse-biased by the battery. The test device emitter is open-circuited. Meter M1 indicates the collector current. With function switch' at ICO X10, shunt resistor R28 and series resistor R29 are connected to the meter. The sensitivity of the meter is decreased by 10.

5-6. DIODE 1-10 Ratio Check

a. A simplified schematic diagram of the circuit used to check diodes for a 10 :1, front-to-back ratio is shown on figure 5-5. A, figure 5-5, illustrates the circuit used to obtain the forward or reference, reading and B, figure 5-5, illustrates the circuit used to obtain the reverse reading.

b. The 10:1 ratio measurement is obtained in the following manner. The test device is placed in series with the meter and its shunt and current limiting resistors in both forward and reverse positions. With the polarity switch in the FWD PNP position, the

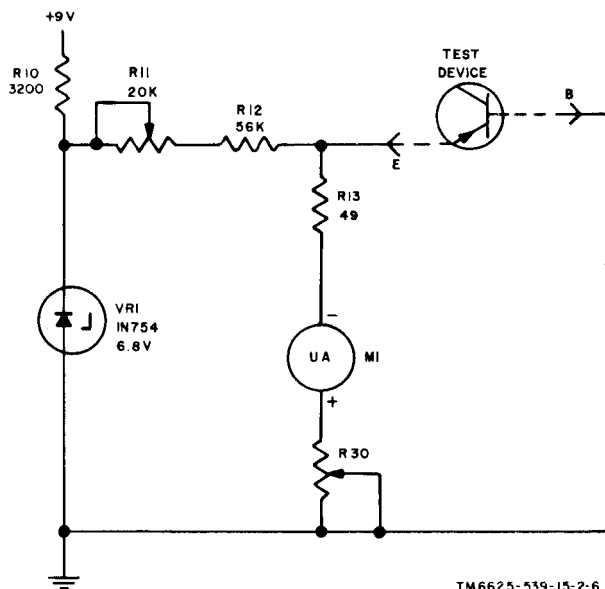

TM 6625-539-15-2-6

Figure 5-3. Resistance check, simplified schematic diagram.

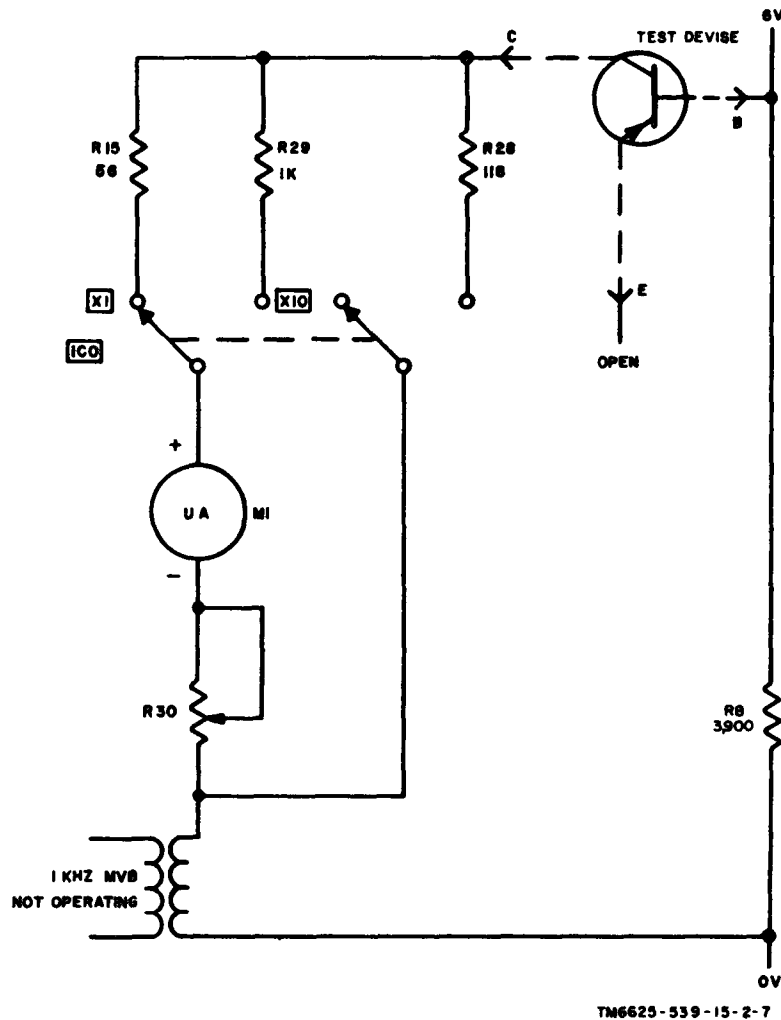

Figure 5-4 I_o (leakage) check, simplified schematic diagram.

diode is forward-biased and conducts heavily. Resistors R9, R5, meter shunt R27, and the forward resistance of the test device limit the current through meter M1. CAL potentiometer R5 is adjusted to set the current through M1 to 100 ma which corresponds to a full-scale meter reading. After CAL potentiometer R5 has been set to provide a full-scale reading, the polarity switch is set to NPN REV as shown in B, figure 5-5. The circuit is essentially the same as the circuit used to obtain the reference reading; the only change is the reversal of the applied voltage and reversal of the meter. The test device is now back-biased and offers a high resistance. Circuit current is proportionally decreased because of the increased resistance of the test device, and consequently, meter deflection is proportionally reduced. The forward-

to-reverse current ratio is read directly on the BETA scale of the meter.

5-7. F.E.T. CAL Check

a. A schematic diagram of the circuit used to calibrate the test set for field effect transistor (F. E.T.) transconductance measurement is shown in figure 5-6. Figure 5-6 shows an N-channel F.E.T. transistor; however, the same principle applies for a P-channel F.E.T. transistor.

b. The F.E.T. CAL position of the function switch sets the signal level applied to the test device at 100 millivolts (mv) as follows. The 1-kHz multivibrator applies a symmetrical square wave between the source and the gate of the F.E.T. under test. A voltage divider, consisting of resistors R18 and R17, shunts the source gate junction of the test device; a portion of the 1-kHz square wave applied between

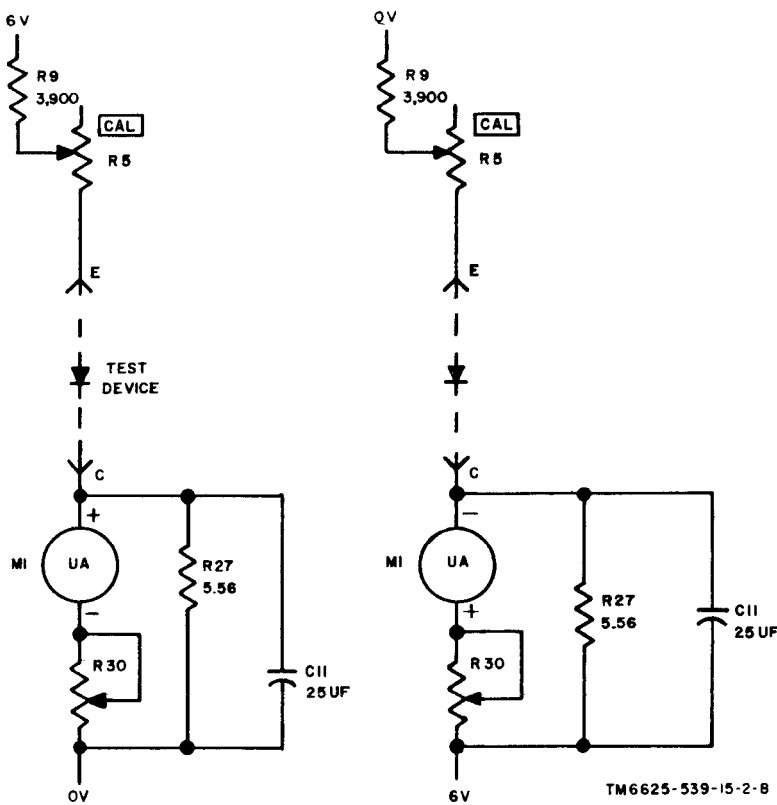
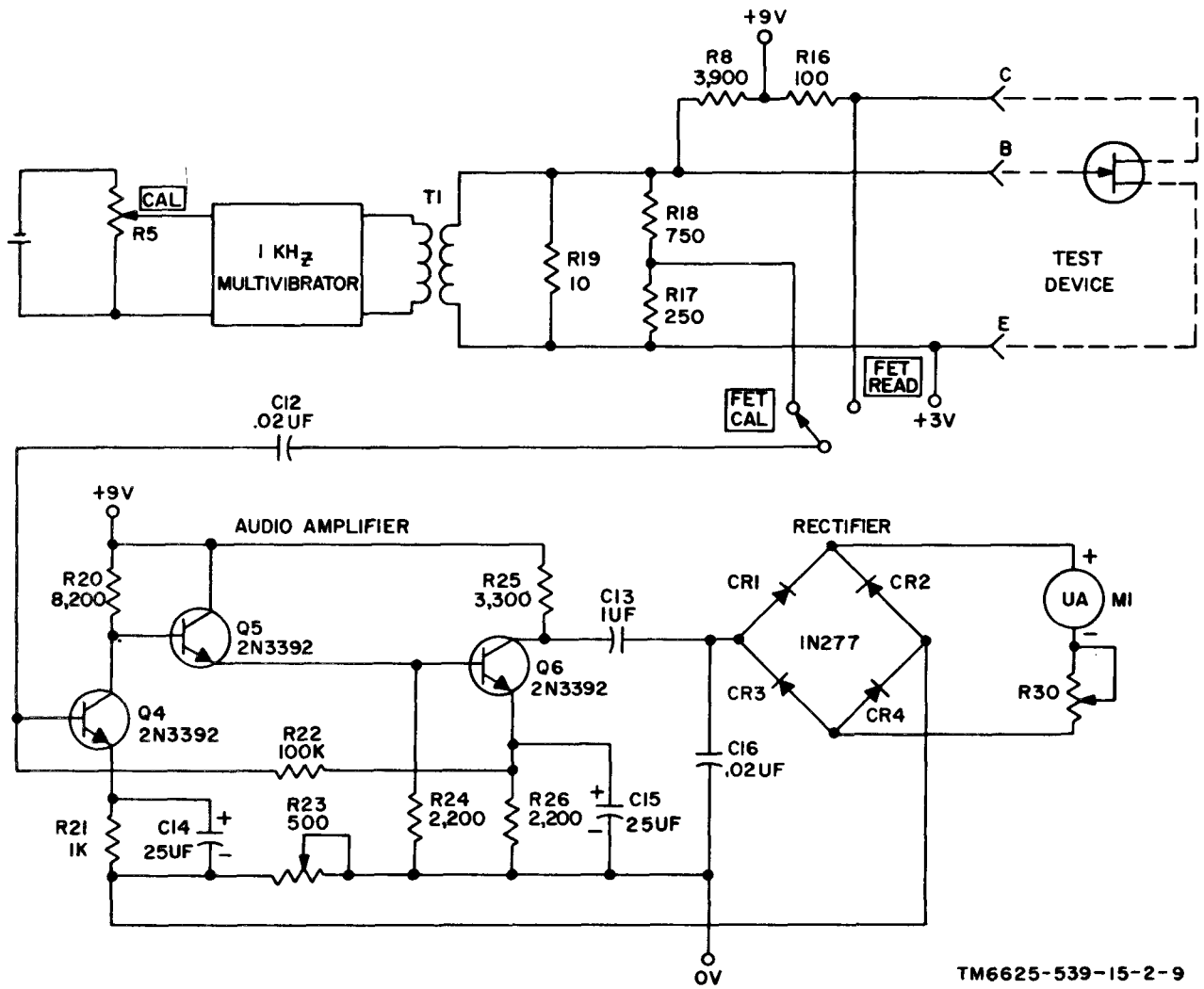

Figure 5-5. Diode 1:10 ratio check, simplified schematic diagram.

the source and the gate is picked off at the junction of R17 and R18 and is applied to the input of audio amplifier Q4, Q5, and Q6. The output of the audio amplifier is rectified by bridge CR1, CR2, CR3, and CR4 and is applied to the meter. A full scale meter reading indicates that the square wave applied to the F.E.T. is 100 mv in amplitude. The output level of the multivibrator (input level to the test device) is varied by adjusting CAL potentiometer R5. The signal level applied to the test device can be accurately set at 100 mv by adjustment of CAL potentiometer R5 while observing the meter for a full scale reading.

5-8. F.E.T. READ Check

GM measurements of field effect transistors are accomplished by the test set in the following manner. The 1-kHz multivibrator, when properly calibrated by adjustment of CAL potentiometer R5, applies a symmetrical 100-mv square wave between the source and gate of the test device. Operating voltages are also applied to the test device. The 1-kHz square wave appearing at the drain of the test device is applied to the input of the audio amplifier. The output of the audio amplifier is rectified by bridge CR1, CR2, CR3, and CR4 and is applied to the meter. The meter is calibrated directly in GM micromhos.



TM6625-539-15-2-9

Figure 5-6. F.E.T. checks, simplified schematic diagram.

CHAPTER 6

TROUBLESHOOTING AND REPAIR

6-1. Troubleshooting Techniques

a. General. The first procedure in servicing a defective test set is to sectionalize the fault. Sectionalization consists of tracing the fault to a group of circuits concerned with one test function. Once the defective function is found, isolation to the defective part is accomplished. Troubleshooting is performed by general support and depot repairmen.

b. Sectionalization. Listed in (1) and (2) below is a group of tests that are arranged to help locate the defect to a faulty component.

(1) *Visual inspection.* When the test set is brought in for repair, remove the front panel and inspect as follows:

(a) Check to see that all connections are properly seated. Repair or replace any connections or leads that are broken or otherwise defective.

(b) Check all switches and controls for ease of operation.

(c) Remove the access cover to the batteries, and check for corrosion and looseness of batteries.

(d) Inspect for loose or missing screws, specifically those that fasten the rear parts board in place.

(2) *Operational tests.* Operational tests frequently indicate the general location of trouble. In many instances, the test will determine the exact nature of the fault. The operator's preventive maintenance checks and operation check (para 4-4) and the alignment procedures (para 7-1 through 7-4) provide a good operational test.

(3) *Troubleshooting chart and equipment required.* The meter indications, or lack of meter indications, and operational checks provide a systematic method of localizing trouble to the faulty circuit. The trouble symptoms listed in the troubleshooting chart (para 6-2) provide additional information for localizing troubles. The only test equipment required is Voltmeter, Electronic ME-30(*)/U (TM 11-6625-320-12).

NOTE

Voltmeter, Electronic ME-30(*)/U represents Voltmeter, Meter ME-30A/U and Voltmeters, Electronic ME-30B/U, ME-30/U, and ME-30E/U.

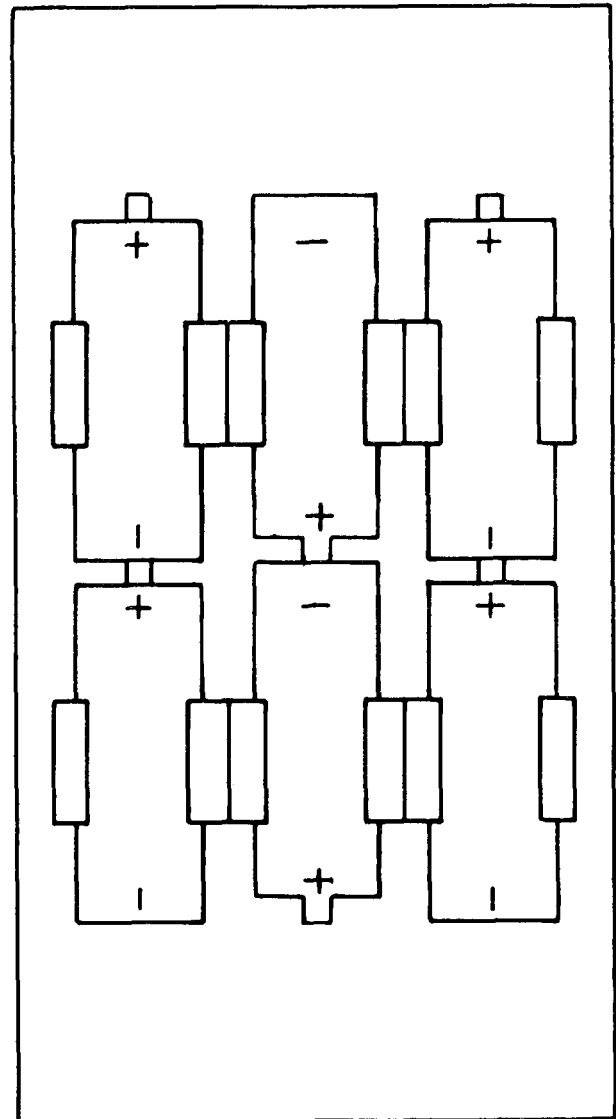

EL6625-539-15-2-C2-TM-10

Figure 6-1. Battery polarity and location, battery compartment.

6-2. Troubleshooting Chart

<i>Symptom</i>	<i>Probable cause</i>	<i>Corrective measure</i>
Meter pointer does not fall within BAT position on scale with function switch on BAT.	Batteries loose or weak. Meter M1 defective.	Check batteries (fig. 6-1). Check meter M1.
Meter pointer does not align (para 7-2). ME-30(*)/ U does not indicate 100 mv (para 7-3).	VR1, R10, R11, or R13 defective Q1, Q2, Q3, on T1, or associated circuitry defective (figs. 5-6 and 7-1).	Check VR1, R10, R11, and R13. Check Q1, Q2, Q3, T1, and associated circuitry.
Meter pointer does not indicate full scale (para 7-3).	Q4, Q5, Q6, CR1, CR2, CR3, CR4, or associated circuitry defective.	Check Q4, Q5, Q6, and CR1 through CR4.

CHAPTER 7

ALIGNMENT PROCEDURES

7-1. General

Under normal conditions, the test set will maintain the factory alignment over a long period of time. It is necessary to realign the test set if any component except the batteries is changed. Alignment procedures are given in paragraphs 7-2 through 7-4.

7-2. Alignment of Meter Zero

- a. Set the polarity switch to OFF.
- b. Adjust the meter zero adjustment screw located directly below the base of the pointer for a 0 meter indication.

7-3. Alignment of Meter OHMS Position

a. *Test Equipment Required.* The only test equipment required is a 100-ohm, ± 1 percent, $\frac{1}{2}$ -watt resistor, FSN.

- b. *Procedure.*
 - (1) Disconnect the unit from the case by removing the four front panel screws.
 - (2) Set the polarity switch to FWD PNP.
 - (3) Set the function switch to OHMS E-B.
 - (4) Adjust resistor R11 (fig. 7-1) so that the meter pointer indicates full scale on the OHMS scale.

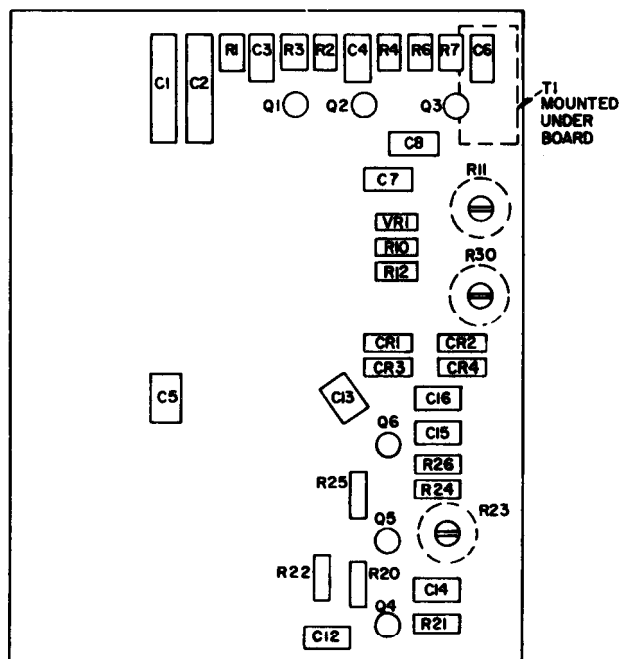

Figure 7-1. Component location, board mounted.

TM 11-6625-539-15-2

(5) Place the 100-ohm, ± 1 percent, $\frac{1}{2}$ -watt resistor between the E and B jacks on the front panel.

(6) Adjust resistor R30 so that meter M indicates 100 ohms.

(7) Remove the 100-ohm resistor, and check to see that the meter pointer indicates full scale. If the meter pointer does not indicate full scale, repeat the procedures in (2) through (6) above.

7-4. Alignment of Test Set F.E.T. Position

a. Test Equipment Required. An ME-30(*) /U is required.

b. Procedure.

(1) Disconnect the unit from the case by removing the four panel screws.

(2) Set the polarity switch to FWD PNP.

(3) Set the function switch to F.E.T. CAL.

(4) Place the ME-30(*)/U across the E and B jacks on the front panel.

(5) Adjust CAL control R5 (fig. 7-2) and resistor R23 (fig. 7-1) so that the meter pointer indicates full scale when the ME-30(*)/U indicates 100 mv.

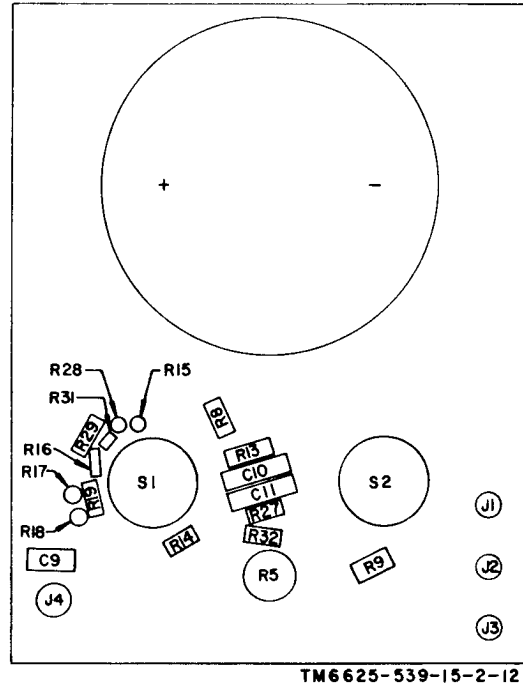

Figure 7-2. Component location, panel mounted.

CHAPTER 8

GENERAL SUPPORT TESTING PROCEDURES

8-1. General

a. Testing procedures are prepared for use by Electronic Field Maintenance Shops and Electronic Service Organizations responsible for general support maintenance of electronic equipment to determine the acceptability of repaired equipment. These procedures set forth specific requirements that repaired equipment *must* meet before it is returned to the using organization.

b. Comply with the instructions preceding each chart before proceeding to the chart. Perform each step in sequence. Do not vary the Sequence. For each step, perform all the actions required in the *Control settings* columns; then perform each specific test procedure, and verify it against its performance standard.

c. Procedure.

Step No.	Test equipment	Control settings	Test procedure	Performance standard
1	None-----	Equipment under test Controls may be in any position.	a. Inspect case and chassis for damage, missing parts, and defective condition of paint. Note. Touchup painting is recommended in place of refinishing whenever practical; screw-heads, binding pins, receptacles, and other plated parts will not be painted or polished with abrasives. b. Inspect all controls and mechanical assemblies for loose or missing screws, bolts, and nuts. c. Inspect all connectors, sockets, receptacles, and fuseholders and meter for looseness, damage, or missing parts.	a. No damage evident or parts missing. External surfaces intended to be painted do not show bare metal. b. Screws, bolts, and nuts will be tight with none missing. c. No loose parts or damage. No missing parts.
2	None-----	Controls may be in any position.	a. Rotate all panel controls throughout their limits of travel. b. Inspect dial stops for damage or bending; check for proper operation. c. Operate switches-----	a. Controls rotate freely without binding or excessive looseness. b. Stops operate properly without evidence of damage. c. Switches operate properly.
3	MX-1292/PAQ Connect mercury vapor lamp.	Controls may be in any position.	Turn on mercury vapor lamp and expose portion of equipment that has been repaired or disturbed to direct rays of lamp.	All repaired or disturbed electrical components and chassis surfaces are covered. There must be no varnish on switch contacts or moving parts of mechanical assemblies. Note. Moisture-fungus-proofing varnish glows gray-green under rays of mercury vapor lamp.

8-2. Test Equipment and Material

The only test equipment and material required for testing the T.S-1836B/U is Voltmeter, Electronic ME-30(*)/U and a 100-ohm, ±1 percent, ½-watt. resistor.

8-3. Modification Work Orders

The performance standards listed in the tests (paras 8-5 and 8-6) are based on the assumption that all modification work orders have been performed. DA Pam 310-7 lists current MWO's.

8-4. Physical Tests and Inspection

- a. *Test Equipment and Materials.* None required.
- b. *Test Connection and Conditions.*
 - (1) No connections are necessary.
 - (2) Remove the test set chassis from its case.

8-5. Meter OHMS Position Test

- a. *Test Equipment and Materials.* A 100-ohm, ± 1 percent, 1/2-watt resistor is required.
- b. *Test Connections and Conditions.* No connections are necessary other than those indicated in c below.
- c. *Procedure.*

Step No.	Control settings		Test procedure	Performance standard
	Test equipment	Equipment under test		
1	None -----	Polarity switch: FWD PNP. Function switch: OHMS E--B.	Observe the meter -----	Meter pointer indicates full scale on the OHMS scale.
2	None-----	Same as step 1-----	Place the 100-ohm, resistor between the E and B jacks on the front panel. Observe the meter.	Meter indicates 100 ohms $\pm 5\%$
3	None -----	Same as step 1-----	Remove the 100-ohm resistor, and observe the meter.	Same as step 1.

8-6. Test Set F.E.T. Position Test

- a. *Test Equipment and Materials.* The only test equipment required is Voltmeter, Meter ME-30(*)/U.
- b. *Test Connections and Conditions.* Connect the equipment as instructed below.

c. *Procedure.*

Step No.	Control settings		Test procedure	Performance standard
	Test equipment	Equipment under test		
1	ME-30(*)/U Range selector switch: 3.	Polarity switch: FWD PNP. Function switch: F.E.T. CAL.	Connect the ME-30(*) /U across the E and B Jacks. Observe the indication on the ME-30(*)/U meter.	ME-30(*)/U indicates 100 mv (0.1 volt) $\pm 5\%$.

CHAPTER 9

DEPOT OVERHAUL STANDARDS

9-1. Applicability of Depot Overhaul Standards

The tests outlined in this chapter are designed to measure the performance capability of a repaired equipment. Equipment that is to be returned to stock should meet the standards given in these tests.

9-2. Applicable References

a. Repair Standards. Applicable procedures of the depots performing these tests, and the general standards for repaired electronic equipment given in TB SIG 355-1, TB SIG 355-2, and TB SIG 355-3 form a part of the requirements for testing this equipment.

b. Modification Work Orders. Perform all modification work orders applicable to this equipment *before* making the tests specified. DA Pam 310-7 lists all available MWO'S.

9-3. Test Facilities Required

The only test, facilities required for depot testing are Voltmeter, Meter ME-30(*)/U and a 100-ohm ± 1 percent, $\frac{1}{2}$ -watt resistor.

9-4. Depot Overhaul Standards Tests

For depot overhaul standards tests, perform the tests in paragraphs 8-5 and 8-6.

CHAPTER 10

SHIPMENT AND LIMITED STORAGE AND DEMOLITION TO PREVENT ENEMY USE

Section I. SHIPMENT AND LIMITED STORAGE

10-1. Disassembly of Equipment

Disassembly procedures for Test Set, Transistor TS-M36B/U consist of the procedures in a through c below.

- a. Disconnect the three test leads, and place them in the storage space in the top of the instrument case.
- b. Remove the front panel and top to the battery compartment. Remove the six batteries. Replace the top to the battery compartment and front panel, being careful to tighten all screws securely.
- c. Set the polarity switch to OFF.

10-2. Repackaging for Shipment or Limited Storage

The exact procedure for repackaging depends on the material available and whether the equipment is to be shipped or stored. Adapt the procedures outlined in a through c below whenever possible. The infor-

mation concerning the original packaging (para 2-1) will be helpful.

a. *Material Requirement.* The materials listed in the chart below are required for packaging Test Set, Transistor TS-1836B/U. For stock numbers of materials, consult SB 38-100.

<i>Material</i>	<i>Quantity</i>
Waterproof paper -----	6 sq ft.
Waterproof tape -----	4 ft.
Cotton twine -----	12 ft.
Corrugated cardboard -----	6 sq ft.
Gummed tape -----	4 ft.
Filler material -----	3 lb.

b. *Packaging.* The test set shall be packed on all surfaces with pads of filler material. Place the cushioned unit within a wrap of corrugated cardboard. Secure the corrugated cardboard with gummed tape.

c. *Packing.* Wrap the package in waterproof paper, seal it with waterproof tape, and place it in a nailed wooden box.

Section II. DEMOLITION OF MATERIEL TO PREVENT ENEMY USE

10-3. Authority for Demolition

a. The demolition procedures given in paragraph 10-4 will be used to prevent the enemy from using or salvaging this equipment. Demolition of the equipment will be accomplished only upon the order of the commander.

b. Thorough demolition of equipment will be accomplished through the procedures outlined in International Standardization Agreement STANG 2113, *Destruction of Military Technical Equipment*. Methods of destruction should damage equipment and essential spare parts. so that it will not be possible to restore the equipment to a usable condition in the combat zone either by repair or cannibalization. Reporting of destruction of equipment is to be done through command channels.

c. If a destruction plan is not provided by higher authority one should be prepared by the organization

using the equipment. In this plan, personnel should be assigned specific destruction tasks, but all personnel in the using organization should be familiar with all aspects of the complete destruction plan. The plan must be adequate and easily carried out in the field and must provide for as complete a destruction as available time, equipment, and personnel will permit. Because the time required for complete destruction may not always be available, the destruction plan must establish priorities so that essential parts of the equipments will be destroyed in the order of their importance. Systematic destruction of the same important units of equipment of a given type will prevent the enemy from learning the important features of the equipment or assembling a complete equipment by cannibalization of partially destroyed equipment. Adequate destruction of some units of equipment should always be accomplished rather than partial destruction of all units. The method listed in para-

graph 10-4 which is to be used depends on the time available for destruction.

10-4. Methods of Destruction

a. Destruction Priority. STANAG 2113 outlines the general priorities for any equipment which is to be destroyed.

b. Smash. Smash the controls, resistors, capacitors, switches, and other interior parts; use sledges, hammers, axes, crowbars, or other heavy tools.

c. Cut. Cut the cords, cables, and wiring; use axes, handaxes, or machetes.

***Warning:* Be extremely careful with explosive and incendiary devices. Use these items only when the need is urgent.**

d. Burn. Burn the cords, wiring, technical manuals, and components; use gasoline, kerosene, oil, flamethrowers, or incendiary grenades.

e. Bend. Bend the panels, casing, and connectors.

f. Explosives. If explosives are necessary, use fire+ arms, grenades, or TNT.

g. Disposal Burn or scatter the destroyed parts in slit trenches, foxholes, or other holes, or throw them into nearby streams.

COLOR CODE MARKING FOR MILITARY STANDARD RESISTORS

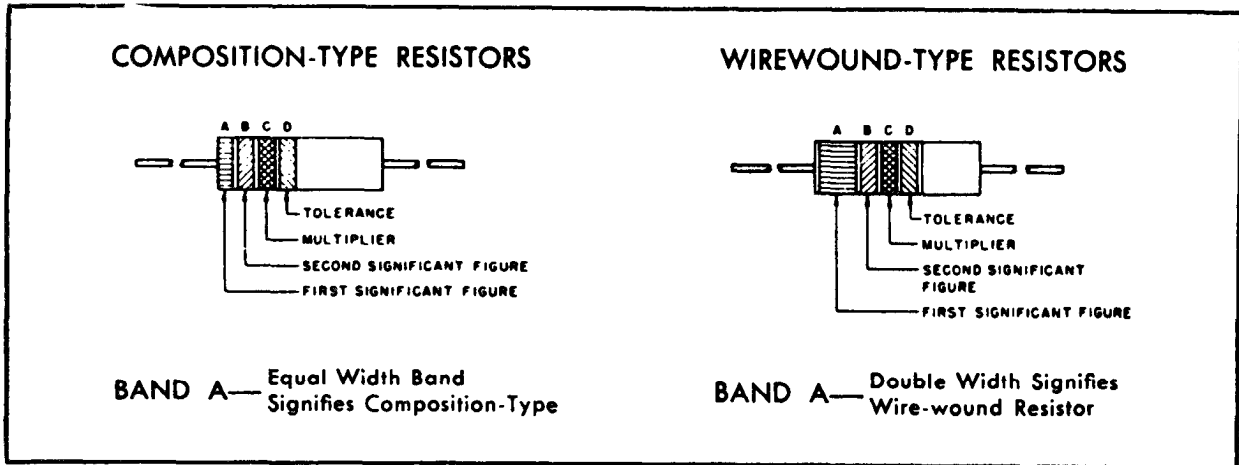

COLOR CODE TABLE

BAND A		BAND B		BAND C		BAND D*	
COLOR	FIRST SIGNIFICANT FIGURE	COLOR	SECOND SIGNIFICANT FIGURE	COLOR	MULTIPLIER	COLOR	RESISTANCE TOLERANCE (PERCENT)
BLACK	0	BLACK	0	BLACK	1		
BROWN	1	BROWN	1	BROWN	10		
RED	2	RED	2	RED	100		
ORANGE	3	ORANGE	3	ORANGE	1,000		
YELLOW	4	YELLOW	4	YELLOW	10,000	SILVER	+ 10
GREEN	5	GREEN	5	GREEN	100,000	GOLD	± 5
BLUE	6	BLUE	6	BLUE	1,000,000		
PURPLE (VIOLET)	7	PURPLE (VIOLET)	7				
GRAY	8	GRAY	8	SILVER	0.01		
WHITE	9	WHITE	9	GOLD	0.1		

EXAMPLES OF COLOR CODING

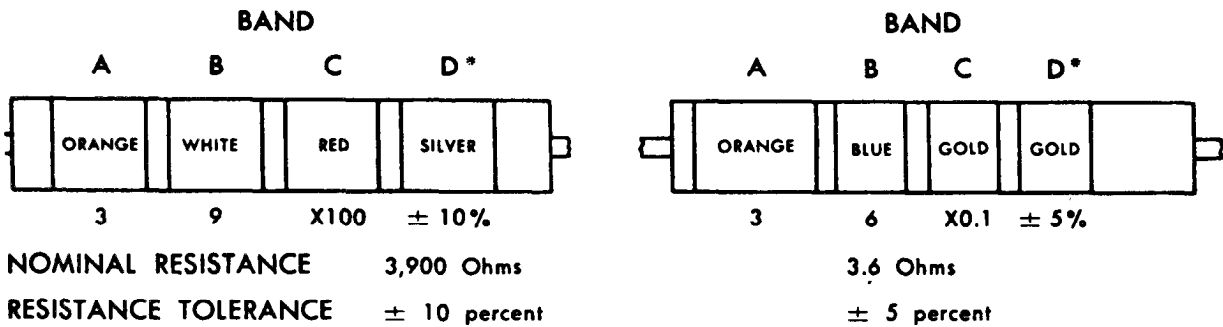

*If Band D is omitted, the resistor tolerance is ± 20%, and the resistor is not Mil-Std.

STD-R2

Figure 10-1. Color-code marking for MIL-STD resistors.

APPENDIX A
REFERENCES

DA Pam 310-4	Index of Technical Manuals, Technical Bulletins, Supply Manuals (types 7,8, and 9), Supply Bulletins, and Lubrication Orders..
DA Pam 310-7	US Army Equipment Index of Modification Work Orders.
SB 38-100	Preservation, Packaging, Packing and Marking Materials, Supplies, and Equipment Used by the Army.
TB SIG 355-1	Depot Inspection Standard for Repaired Signal Equipment.
TB SIG 355-2	Depot Inspection Standard for Refinishing Repaired Signal Equipment.
TB SIG 355-3	Depot Inspection Standard for Moisture and Fungus Resistant Treatment.
TB 43-0118	Field Instructions for Painting and Preserving Electronics Command Equipment Including Camouflage Pattern Painting of Electrical Equipment Shelters.
TM 11-6625-320-12	Operator's and Organizational Maintenance Manual: Voltmeter, Meter ME-30A/U and Voltmeters, Electronic ME-30B/U, ME-30C/U, and ME-30E/U.
TM 38-750	The Army Maintenance Management System (TAMMS).
TM 740-90-1	Administrative Storage of Equipment.
TM 750-244-2	Procedures for Destruction of Electronics Materiel to Prevent Enemy Use (Electronics Command).

APPENDIX C

MAINTENANCE ALLOCATION

Section I. INTRODUCTION

C-1. General

This appendix provides a summary of the maintenance operations for the Test Set, Transistor TS-1836B/U. It authorizes categories of maintenance for specific maintenance functions on repairable items and components and the tools and equipment required to perform each function. This appendix may be used as an aid in planning maintenance operations.

C-2. Maintenance Function

Maintenance functions will be limited to and defined as follows:

a. Inspect. To determine the serviceability of an item by comparing its physical, mechanical, and/or electrical characteristics with established standards through examination.

b. Test. To verify serviceability and to detect incipient failure by measuring the mechanical or electrical characteristics of an item and comparing those characteristics with prescribed standards.

c. Service. Operations required periodically to keep an item in proper operating condition; i.e., to clean, preserve, drain, paint, or to replenish fuel/lubricants/hydraulic fluids or compressed air supplies.

d. Adjust. Maintain within prescribed limits by bringing into proper or exact position, or by setting the operating characteristics to the specified parameters.

e. Align. To adjust specified variable elements of an item to about optimum or desired performance.

f. Calibrate. To determine and cause corrections to be made or to be adjusted on instruments or test measuring and diagnostic equipment used in precision measurement. Consists of the comparison of two instruments, one of which is a certified standard of known accuracy, to detect and adjust any discrepancy in the accuracy of the instrument being compared.

g. Install. The act of emplacing, seating, or fixing into position an item, part, module (component or assembly) in a manner to allow the proper functioning of the equipment/system.

h. Replace. The act of substituting a serviceable like-type part, subassembly, model (component or assembly) for an unserviceable counterpart.

i. Repair. The application of maintenance services (inspect, test, service, adjust; align, calibrate, replace) or other maintenance actions (welding, grind-

ing, riveting, straightening, facing, remachining, or resurfacing) to restore serviceability to an item by correcting specific damage, fault, malfunction, or failure in a part, subassembly, module/component/assembly, end item or system. This function does not include the trial and error replacement of running spare type items such as fuses, lamps, or electron tubes.

j. Overhaul. That periodic maintenance effort (service/action) necessary to restore an item to a completely serviceable/operational condition as prescribed by maintenance standards (e.g., DMWR) in appropriate technical publications. Overhaul is normally the highest degree of maintenance performed by the Army. Overhaul does not normally return an item to like-new condition.

k. Rebuild. Consists of those services/actions necessary for the restoration of unserviceable equipment to a like-new condition in accordance with original manufacturing standards. Rebuild is the highest degree of material maintenance applied to Army equipment. The rebuild operation includes the act of returning to zero those age measurements (hours, miles, etc.) considered in classifying Army equipment/components.

C-3. Column Entries

a. Column 1, Group Number. Column 1 lists group numbers, the purpose of which is to identify components, assemblies, subassemblies and modules with the next higher assembly.

b. Column 2, Component/Assembly. Column 2 contains the noun names of components, assemblies, subassemblies, and modules for which maintenance is authorized.

c. Column 3, Maintenance Functions. Column 3 lists the functions to be performed on the item listed in column 2. When items are listed without maintenance functions, it is solely for purpose of having the group numbers in the MAC and RPSTL coincide.

d. Column 4, Maintenance Category. Column 4 specifies, by the listing of a "worktime" figure in the appropriate subcolumn(s), the lowest level of maintenance authorized to perform the function listed in column 3. This figure represents the active time required to perform that maintenance function at the indicated category of maintenance. If the number or complexity of the tasks within the listed

maintenance function vary at different maintenance categories, appropriate "worktime" figures will be shown for each category. The number of task-hours specified by the "worktime" figure represents the average time required to restore an item (assembly, subassembly, component, module, end item or system) to a serviceable condition under typical field operating conditions. This time includes preparation time, troubleshooting time and quality assurance quality control time in addition to the time required to perform the specific tasks identified for the maintenance functions authorized in the maintenance allocation chart. Subcolumns of column 4 are as follows:

- C - Operator/crew
- O - Organizational
- F - Direct support
- H - General support
- D - Depot

e. Column 5, Tools and Equipment. Column 5 specifies by code, those common tool sets (not individual tools) and special tools, test, and support equipment required to perform the designated

function.

C-4. Tool and Test Equipment Requirements (Table 1)

a. Tool or Test Equipment Reference Code. The numbers in this column coincide with the numbers used in the tools and equipment column of the MAC. The numbers indicate the applicable tool or test equipment for the maintenance functions.

b. Maintenance Category. The codes in this column indicate the maintenance category allocated the tool or test equipment.

c. Nomenclature. This column lists the noun name and nomenclature of the tools and test equipment required to perform the maintenance functions.

d. National/NATO Stock Number. This column lists the National/NATO stock number of the specific tool or test equipment.

e. Tool Number. This column lists the manufacturer's part number of the tool followed by the Federal Supply Code for Manufacturers (5-digit) in parentheses.

SECTION II MAINTENANCE ALLOCATION CHART
 FOR
 TEST SET, TRANSISTOR TS-1836B/U

(1) GROUP NUMBER	(2) COMPONENT/ASSEMBLY	(3) MAINTENANCE FUNCTION	(4) MAINTENANCE CATEGORY					(5) TOOLS AND EQUIPMENT
			C	O	F	H	D	
00	TESTSET, TRANSISTOR TS-1836B/U	Inspect		0.5				4
		Service ¹		1.0				4
		Test ²		0.5				1
		Test ²				1.0		2,5,6
		Service ³		0.2				4
		Repair Overhaul				1.5		2,3,5,6
01	CASE ASSEMBLY (UPPER)	Test				0.2		2,3
		Repair				0.8		3
02	PANEL ASSEMBLY	Test				0.2		2
		Repair				0.8		3
0201	ELECTRONIC COMPONENTS ASSEMBLY	Test				0.8		2,3
		Repair				1.3		2,3,6

(1) Operational tests.
 (2) All tests.
 (3) By replacement of knobs.

TABLE 1. TOOL AND TEST EQUIPMENT REQUIREMENTS FOR

TEST SET, TRANSISTOR TS-1836B/U

TOOL OR TEST EQUIPMENT REF CODE	MAINTENANCE CATEGORY	NOMENCLATURE	NATIONAL/NATC STOCK NUMBER	TOOL NUMBER
1	O	MULTIMETER AN/URM-1 05C	625-00-999-6282	
2	H,D	MULTIMETER TS-352B/U	625-00-553-0142	
3	H,D	TOOL KIT ELEC EQUIP TK-100/G	180-00-605-0079	
4	O	TOOLS AND TEST EQUIP AVAILABLE TO REPAIRPERSON USER BECAUSE OF HIS/HER ASSIGNED MISSION		
5	H,D	VOLTMETER , ELECTRONIC ME-30/U	625-00-643-1670	
6	H,D	TEST SET , TRANSISTOR TS-1836/U	625-00-893-2628	

APPENDIX E

TRANSISTOR CHARACTERISTIC DATA FOR

TEST SET, TRANSISTOR TS-183613/U

Two of the most important parameters for testing transistors in circuit are I_{co} and beta. Minimum value of beta and maximum values of I_{co} are presented as an aid in determining faulty transistor and transistors that have started to degrade.

Beta is normally specified by the manufacturer at various collector-to-emitter voltages; however, beta is normally independent of collector-to-emitter voltage above the saturation voltage. The magnitude of the beta of a transistor, therefore, measured at a potential slightly above the saturation voltage is very close to the magnitude of the beta measured at some higher potential. The appendix shows data gathered from manufacture and specification sheets which accounts for the various potentials for which beta is given. The same reasoning is true for

the I_{co} parameter if it does not contain a leakage current. A plot of collector current versus collector voltage of a reverse-biased collector-to-base junction with a negligible amount of leakage current yields a graph which rises to some current rather quickly and then remains constant with increasing voltage until the breakdown voltage of the junction is reached. A leakage component across the junction modifies this curve in an amount depending on the amount of leakage present across the junction. The figure of 6 volts was chosen as one that would give maximum information on the largest amount of transistors and diodes. A device with a lower breakdown voltage than 6 volts will not be damaged since the power, when this measurement is made, is limited to less than 5 milliwatts.

TYPE NO.	I _{CBO} (μ A)	h_{fe}	PNP- DWG. NPN NO	TYPE NO.	I _{CBO} (μ A)	h_{fe}	PNP- DWG. NPN NO.
2N34	50	75	PNP T022	2N122	10	30	NPN C306
2N34A		60	PNP	2N123	60	75	PNP B222
2N35	50	75	NPN T022	USAF2N123	60	30	PNP B222
2N36		45	PNP	2N124	20	18	NPN A107
2N37		30	PNP A109	2N125	20	36	NPN A107
2N38		15	PNP A109	2N126	20	20	NPN B218
2N39		42	PNP B222	2N128	30	19	PNP T024
2N43A	70	25	PNP T05	JAN 2N128	15	19	PNP T024
USAF2N43A	16	30	PNP B222	2N130	12	24	PNP T05
2N44	16	25	PNP B222	2N130A	15	26	PNP
2N44A	60	31	PNP B222	2N131	12	50	PNP T05
USAF2N44A	16	13	PNP B222	2N131A	15	45	PNP
2N45	10	12	PNP T029	2N132	12	90	PNP T05
2N59	15	90	PNP T05	2N132A	15	90	PNP
2N59A	15	90	PNP T05	2N133	12	50	PNP T05
2N59B	15	90	PNP T05	2N133A	15	50	PNP
2N59C	15	90	PNP T05	2N135	50	20	PNP B221
2N60	15	70	PNP T05	2N136	50	40	PNP B221
2N60A	15	70	PNP T05	2N137	50	60	PNP B221
2N60B	15	70	PNP T05	2N138	20	44	PNP T022
2N60C	15	70	PNP T05	2N139	10	48	PNP T040
2N61	15	45	PNP T05	2N140	10	75	PNP T040
2N61A	15	45	PNP T05	2N141/13	20	25	PNP T013
2N61B	15	45	PNP T05	2N143/13	50	10	PNP T013
2N61C	15	45	PNP T05	2N144/13	60	11	NPN T013
2N63	20	22	PNP A102	2N145	30		NPN A107
2N64	20	45	PNP A102	2N146	30		NPN A107
2N65	10	75	PNP	2N147	30		NPN A107
2N77	10	55	PNP T01	2N155	10	32	PNP T03
2N78	30	58	NPN A104	2N156	10	25	PNP T013
2N78A	30	58	NPN A104	2N158	10	21	PNP T013
USAF2N78A	30	40	NPN	JAN 2N158	10	12	PNP O401
2N94	50	50	NPN T022	2N158A	10	21	PNP T013
2N94A	50	20	NPN T022	2N160	10	15	NPN A107
2N97	20	13	NPN T05	2N160A	10	15	NPN A107
2N98	20	40	NPN	2N161	10	30	NPN A107
2N101/13	50	11	PNP T013	2N161A	10	30	NPN A107
2N102/13	20	11	NPN T013	2N163	10	78	NPN A107
2N103	50	40	NPN	2N163A	10	78	NPN A107
2N104	10	44	PNP T040	2N164A	50	40	NPN B205
2N105	50	55	PNP T02	2N165	50	72	NPN B205
2N106		45	PNP A103	2N166	50	32	NPN
2N107	10	19	PNP B 221	2N167	15	65	NPN A104
2N108			PNP	2N167A	15	30	NPN A104
2N109	70	65	PNP T040	JAN 2N167A	15	17	NPN A104
2N111		25	PNP A103	2N168A	50	40	NPN A104
2N111A		25	PNP	2N169	50	72	NPN A104
2N112		30	PNP A103	2N169A	50	90	NPN A104
2N112A		30	PNP	2N170	30	20	NPN A104
2N113		45	PNP A103	2N172	30		NPN A107
2N114		75	PNP A103	2N173	40	35	PNP T036
2N117	20	15	NPN A105	2N174	40	25	PNP T036
USN 2N117	10	70	NPN A105	JAN 2N174	15	40	PNP T06
2N118	20	29	NPN A105	2N174A	80	40	PNP T036
JAN 2N118	10	20	NPN A105	2N175	12	65	PNP T040
USN 2N118	10	14	NPN A105	2N176	30	25	PNP T03
2N118A	10	54	NPN A105	2N178	30	15	PNP T03
2N119	20	63	NPN A105	2N180	10	60	PNP
USN 2N119	10	70	NPN A105	2N181	10	60	PNP
2N120	20	200	NPN A105	2N182		25	NPN

TYPE NO.	I _{CBO} (μ A)	h _{fe}	PNP- DWG. NPN NO	TYPE NO.	I _{CBO} (μ A)	h _{fe}	PNP- DWG. NPN NO.
2N183		40	NPN	2N251	2.0	30	PNP 103
2N184		60	NPN	2N251A	+.50	25	PNP 103
2N185	14	80	PNP T022	2N252	10		PNP A107
2N186	16	24	PNP B222	2N253	3.0		NPN A107
2N186A	16	24	PNP B222	2N254	3.0		NPN A107
2N187	16	36	PNP B222	2N255	1.0	30	PNP 103
2N187A	16	36	PNP B222	2N255A	5.0	30	PNP 103
2N188	16	54	PNP B222	2N256	1.0	30	PNP 103
2N188A	16	54	PNP B222	2N256A	5.0	30	PNP 103
2N189	16	32	PNP B222	2N257	2.0	40	PNP 103
2N190	16	42	PNP B222	2N257B	5.0	50	PNP 103
2N191	16	67	PNP B222	2N257C	5.0	40	PNP 103
2N192	16	90	PNP B222	2N257W	5.0	60	PNP 103
2N193	50	7.5	NPN T022	2N263	50	45	NPN A101
2N194	25	8.	NPN T022	2N264	50	20	NPN A101
2N194A	50	8.	NPN T022	2N265	16	115	PNP B222
2N206	10	47	PNP T01	2N268	2.0	40	PNP 103
2N207	15		PNP T05	2N268A	2.0	20	PNP 103
2N207A	10	100	PNP T05	2N269	20	40	PNP 101
2N207B	10	100	PNP T05	2N270	16	70	PNP B219
2N211	20		NPN T022	2N271		45	PNP
2N212	50	20	NPN T022	2N271A		45	PNP
2N213	50	60	NPN T022	2N272	10	120	PNP 105
2N213A	50	185	NPN T022	2N273	10	20	PNP 105
2N214	50	75	NPN T022	2N274	8.0	60	PNP 1044
2N214A	50	100	NPN T05	USA 2N274	8.0	60	PNP 1044
2N215	14	65	PNP T01	2N277	8.0	35	PNP 1036
2N216	50	7.5	NPN T022	2N278	4.0	35	PNP 1036
2N217	14	75	PNP T01	2N279	12	30	PNP R206
2N218	10	48	PNP T01	2N280	12	47	PNP B206
2N219	10	75	PNP 1044	2N281	10	70	PNP B205
2N220	12	65	PNP T01	2N283	4.5	40	PNP H205
JAN 2N220	12	40	PNP T01		12	30	PNP B205
2N223	20	110	PNP T025	2N284A	12	47	PNP R205
2N224	25	90	PNP T025		1.0	150	PNP 103
2N226	25	60	PNP T025	2N285B	1.0	150	PNP 103
2N228	100	80	NPN T022	2N291	25	45	PNP A106
2N229	100	75	NPN T022	2N292	5.0	25	NPN A104
2N231	6.0	19	PNP T024	2N293	5.0	25	NPN A104
2N232	6.0	24	PNP T024	2N296	1.0	20	PNP 103
2N233	50	3.5	NPN T022	2N297	5.0	12	PNP 103
2N233A	50	15	NPN T022	2N297A	3.0	40	PNP 103
2N234A		25	PNP T03	JAN 2N297A	3.0	40	PNP 103
2N238A	1.0	40	PNP T03	USA 2N300	3.0	10	PNP 1024
2N238B	1.0	60	PNP T03	2N301	3.0		PNP 103
2N238A	1.0	40	PNP T03	2N301A	3.0		PNP 103
2N236B	1.0	60	PNP T03	2N302	10	45	PNP
2N237	10	50	PNP	2N306	50	75	NPN T022
2N238	20	45	PNP T022	2N307	5.0	20	PNP 103
2N240	3.0	30	PNP T024	2N307A	2.0	30	PNP 103
JAN 2N240	10	3.2	PNP T024	2N308	10		PNP A107
2N241	16	73	PNP B222	2N309	10		PNP A107
2N241A	16	73	PNP B222	2N310	10		PNP A107
2N242	5.0		PNP E505	2N311	60	50	PNP 105
2N243	1.0	20	NPN A101	2N312	60	50	NPN 105
2N244	1.0	59	NPN A101	2N315	25	20	PNP 105
2N247/33	12	60	PNP T033	2N315A	25	35	PNP 105
2N249	25	50	PNP	2N315B	2.0	70	PNP 105
2N250	1.0	30	PNP T03	2N316	25	30	PNP 105
2N250A		25	PNP T03	2N316A	25	35	PNP 105

TYPE NO.	I _{CBO} (μ A)	h _{fe}	PNP- DWG. NPN NO.	TYPE NO.	I _{CBO} (μ A)	h _{fe}	PNP- DWG. NPN NO.
2N317	2.0	40	PNP T05	2N350	3.0		PNP T03
2N317A	25	40	PNP T05	2N350A	3.0		PNP T03
2N319	16	34	PNP T05	2N351	3.0	25	PNP T03
2N320	16	50	PNP T05	2N351A	3.0	25	PNP T03
2N321	16	80	PNP T05	2N356	25	30	NPN T05
2N322	16	44	PNP T05	2N356A	25	35	NPN T05
2N323	16	70	PNP T05	2N357	25	30	NPN T05
2N324	16	88	PNP T05	2N357A	25	40	NPN T05
JAN 2N325	+50	15	PNP E505	2N358	25	30	NPN T05
2N326	+30	15	NPN E505	2N358A	5.0	40	NPN T05
JAN 2N326	+50	15	NPN E505	JAN 2N358A	25	25	NPN T05
2N327A	+10	15	PNP T05	2N359	15	200	PNP T05
2N327B	+001	14	PNP T05	2N360	15	100	PNP T05
2N328A	+10	30	PNP T05	2N361	15	50	PNP T05
JAN 2N328A	1.0	18	PNP T05	2N362	15	90	PNP T05
2N328B	+001	28	PNP T05	2N363	15	50	PNP T05
2N329A	+10	60	PNP T05	2N364	10	15	NPN A107
JAN 2N329A	1.0	36	PNP T05	2N365	10	34	NPN A107
2N329B	+001	14	PNP T05	2N366	10	95	NPN A107
2N330A	1.0	25	PNP T05	2N367		15	PNP T09
2N331	16	15	PNP T09	2N368		34	PNP A107
JAN 2N331	10	30	PNP T09	2N369		95	PNP A107
2N332	2.0	15	NPN T05	2N370	20	60	PNP T07
2N332A	+50	16	NPN T05	2N370/33	10	107	PNP T033
2N333	2.0	29	NPN T05	2N371	20	60	PNP T07
JAN 2N333	2.0	29	NPN T05	2N371/33	10	97	PNP T033
2N333A	+50	30	NPN T05	2N372	20	60	PNP T07
2N334	2.0	54	NPN T05	2N372/33	10	97	PNP T033
2N334A	+50	38	NPN T05	2N373	8.0	60	PNP T07
2N335	2.0	63	NPN T05	2N374	8.0	60	PNP T07
JAN 2N335	2.0	63	NPN T05	2N375	3.0	35	PNP T03
2N335A	+50	52	NPN T05	2N376	3.0	35	PNP T03
2N335B	+50	52	NPN T05	2N376A	3.0	35	PNP T03
2N336	2.0	200	NPN T05	2N377	10	40	NPN T05
JAN 2N336	2.0	200	NPN T05	2N377A	40	40	NPN T05
2N336A	+50	95	NPN T05	2N378	+50	15	PNP T03
2N337	1.0	22	NPN T05	2N379	+50	20	PNP T03
JAN 2N337	1.0	22	NPN T05	2N380	+50	30	PNP T03
2N337A	50	55	NPN T05	2N381	10	60	PNP T05
2N338	1.0	24	NPN T05	2N382	10	90	PNP T05
JAN 2N338	1.0	24	NPN T05	2N383	10	115	PNP T05
2N338A	50	99	NPN T05	2N384	12	60	PNP T044
2N339	1.0	50	NPN T011	JAN 2N384	50	20	PNP T044
2N339A	1.0	53	NPN T011	2N384/33	50	60	PNP T033
2N340	1.0	50	NPN T011	2N385	10	60	NPN T05
2N340A	1.0	53	NPN T011	2N385A	40	70	NPN T05
2N341	1.0	50	NPN T011	2N388	10	150	NPN T05
JSN 2N341	50	15	NPN T011	JAN 2N388	20	60	NPN T05
2N341A	10.0	53	NPN T011	2N388A	40	120	NPN T05
2N342	1.0	20	NPN T011	2N389	10	12	NPN C303
JAN 2N342	10.0	90.	NPN T011	JAN 2N389	10	15	NPN T053
2N342A	1.0	20	NPN T011	SN 2N389		15	NPN C303
JAN 2N342A	1.0	90.	NPN T011	2N389A	10	12	NPN C303
2N342B	1.0	21	NPN T011	2N389/I		12	NPN C303
2N343	1.0	50	NPN T011	2N389A/I		12	NPN C303
JAN 2N343	1.0	28	NPN T011	2N392	8.0		PNP T03
2N343B	1.0	59	NPN T011	2N393	5.0	155	PNP T024
2N344	3.0	22	PNP T024	JAN 2N393	5.0	40	PNP T024
2N345	3.0	66	PNP T024	2N394	100	70	PNP T05
2N346	3.0	10	PNP T024	2N394A	6.0	70	PNP T05

TYPE NO.	I _{CBO} (μ A)	h _{FE}	PNP-DWG. NPN NO.	TYPE NO.	I _{CBO} (μ A)	h _{FE}	PNP-DWG. NPN NO.
2N395	6.0	85	PNP T05	USAF2N433	7.0	45	NPN T05
	6.0	90	PNP T05	2N418	6.0	25	NPN T05
2N396A	100	90	PNP T05	2N438A	10	25	NPN T09
JAN 2N396A	6.0	30	PNP T05	2N439	10	45	NPN T05
2N397	6.0	95	PNP T05	2N439A	10	45	NPN T09
2N398	14	60	PNP T09	2N440	10	40	NPN T05
USN 2N398	50	20	PNP T05	2N440A	10	70	NPN T09
2N398A	50	65	PNP T05	2N441	8.0	20	PNP T036
2N398B	6.0	20	PNP T05	2N442	4.0	20	PNP T036
2N399	1.0	40	PNP T03	2N443	4.0	20	PNP T036
2N400	2.0	50	PNP T03	2N444	25	15	NPN T05
2N401	1.0	40	PNP T03	2N444A	25	30	NPN T05
2N402	15	25	PNP T05	2N445	25	35	NPN T05
2N403	15	35	PNP T05	2N445A	25	90	NPN T05
	20	40	PNP T05	2N446	25	60	NPN T05
JAN 2N404	5.0	30	PNP T05	2N446A	25	150	NPN T05
2N404A	5.0		PNP T05	2N447	25	125	NPN T05
JAN 2N404A	5.0	30	PNP T05	2N447A	25	200	NPN T05
	14	35	PNP T044	2N447A	4.0	200	NPN T05
2N406	14	35	PNP T01	2N448	5.0	25	NPN A104
2N407	14	65	PNP T040	2N449	5.0	72	NPN
2N408	14	65	PNP T01	2N450	6.0	130	PNP T05
2N409	10	48	PNP T040	2N456	2.0	10	PNP T03
2N410	10	48	PNP T01	2N456A	2.0	30	PNP T03
2N411	10	75	PNP T040	ISA 2N456A	.50	30	PNP E504A
2N412	10	75	PNP T01	2N456B	.50	30	PNP T03
2N413	5.0	30	PNP T05	2N457	2.0	10	PNP T03
2N413A		30	PNP T05	2N457A	2.0	30	PNP T03
2N414	5.0	60	PNP T05	ISA 2N457A	.50	30	PNP E504A
2N414A		60	PNP T05	2N457B	.50	30	PNP T03
2N414B	6.0	60	PNP T05	2N458	2.0	10	PNP T03
2N414C	6.0	60	PNP T05	2N458A	2.0	30	PNP T03
2N415	2.0		PNP	ISA 2N458A	.50	30	PNP E504A
2N415A		80	PNP	2N458B	.50	30	PNP T03
2N416	5.0	80	PNP T05	2N459	.50	20	PNP T03
USA 2N416	5.0	80	PNP T05	2N459A	.50	20	PNP T03
2N417	9.0	140	PNP T05	2N460	15	24	PNP T05
USA 2N417	5.0	140	PNP T05	2N461	15	40	PNP T05
2N418	1.5	40	PNP T03	ISAF2N461	10	30	PNP T05
2N419	1.0	9.	PNP T03	ISN 2N463	.30	20	PNP T032
2N420	1.5	40	PNP T03	2N464	15	26	PNP T05
2N420A	.50	40	PNP T03	ISA 2N464	15	26	PNP T05
2N422	15	90	PNP T05	2N465	15	45	PNP T05
USN 2N422	20	30	PNP T05	5A 2N465	20	27	PNP T05
2N424	10	12	NPN C303	2N466	15	90	PNP T05
JAN 2N424	10	15	NPN T083	AN 2N466	20	54	PNP T05
USN 2N424		15	NPN C303	2N467	15	180	PNP T05
2N424/I		12	NPN C303	5A 2N467	20	110	PNP T05
2N42A	10	12	NPN C303	2N470	.50	17	NPN T05
2N424A/I	.10	12	NPN C303	2N471	.50	17	NPN T05
2N425	4.0	30	PNP T05	2N471A	2.0	6.	NPN T05
USA 2N425	4.0	30	PNP T05	2N472	.50	17	NPN T05
2N426	4.0	40	PNP T05	2N472A	.50	6.	NPN T05'
USA 2N426	4.0	40	PNP T05	2N473	.50	35	NPN T05
2N427	4.0	55	PNP T05	2N474	.50	35	NPN T05
USA 2N427	4.0	55	PNP T05	2N498A	.50	20	NPN T05
2N428	4.0	80	PNP T05	2N475		30	NPN T05
JAN 2N428	25	20	PNP T05	2N475A	.50	35	NPN T05
2N428A	4.0	20	PNP T05	2N476	.50	45	NPN T05
USAF2N432	2.0	20	NPN T05	2N477	.50	4'	NPN T05

TYPE NO.	I _{CBO} (μ A)	h _{fe}	PNP- DWG. NPN NO.	TYPE NO.	I _{CBO} (μ A)	h _{fe}	PNP DWG. NPN NO.
2N478		60	NPN T05	2N520A	25	100	PNP T05
2N479	.50	60	NPN T05	2N521	25	7.	PNP T05
2N479A	.50	70	NPN T05	2N521A	25	150	PNP T05
2N480	.50	60	NPN T05	2N522	2.0	120	PNP T05
2N480A	.50	70	NPN T05	2N522A	25	200	PNP T05
2N481	10	50	PNP T05	2N523	2.0	200	PNP T05
2N482	10	50	PNP T05	2N523A	25	250	PNP T05
2N483	10	60	PNP T05	2N524	10	30	PNP T05
2N484	10	90	PNP T05	2N524A	10	23	PNP T05
2N485	10	50	PNP T05	2N525	10	44	PNP T05
2N486	10	100	PNP T05	2N525A	10	30	PNP T05
2N495	.001	9.	PNP T01	2N526	10	64	PNP T05
2N495/18	1.0	15	PNP T018	JAN 2N526	10	44	PNP T05
2N496	.10	9.	PNP T01	2N526A	10	47	PNP T05
2N496/18		15	PNP T018	2N527	10	80	PNP T05
2N497	.01	12	NPN T05	2N527A	10	65	PNP T05
JAN 2N497	10	12	NPN T05	USN 2N528	.05	20	PNP T038
2N497A	100	36	NPN T05	2N529	25	18	PNP T05
2N498	.01	12	NPN T05	2N530	25	23	PNP T05
JAN 2N498	10	12	NPN T05	2N531	25	28	PNP T05
2N498A	100	36	NPN T05	2N532	25	33	PNP T05
2N499	100	8.5	PNP T01	2N533	25	38	PNP T05
USA 2N499	100	8.5	PNP T01	2N535	12	100	PNP T05
2N499A	15	50	PNP T01	2N535A	12	100	PNP T05
USA 2N499A	15	50	PNP T01	2N535B	12	100	PNP T05
2N501	100	70	PNP T01	2N536	12	150	PNP T05
2N501/18	100	20	PNP T018	USA 2N537	100	10	PNP T029
2N501A	25	95	PNP T01	2N538	2.0	20	PNP F632
JAN 2N501A	25	30	PNP T01	2N538A	2.0	20	PNP F632
2N502	20	65	PNP T09	2N539	2.0	30	PNP F632
2N502A	20	65	PNP T09	JAN 2N539	2.0	30	PNP F632
USA 2N502A	20	65	PNP T09	2N539A	2.0	30	PNP F632
2N502B	5.0	20	NPN T09	JAN 2N539A	2.0	30	PNP F632
USA 2N502B	20	20	PNP T09	2N540	2.0	45	PNP F632
2N503	100	45	PNP T09	2N540A	2.0	45	PNP F632
2N504	10	16	PNP T01	2N541	.50	130	NPN T05
2N505		40	PNP T09	2N542	.50	130	NPN T05
2N506	15	40	PNP	2N542A	.50	80	NPN T05
2N507	15	25	NPN T022	2N543	.50	130	NPN T05
2N508	7.0	120	PNP T05	2N543A	.50	140	NPN T05
2N508A	7.0	120	PNP T05	2N544/33		97	PNP T033
2N511	15	20	PNP E503	2N545	15	25	NPN T05
2N511A	15	20	PNP E503	USN 2N545	15	15	NPN T05
2N511B	15	20	PNP E503	2N546	15	25	NPN T05
2N512	15	20	PNP E503	2N547	15	35	NPN T05
2N512A	15	20	PNP E503	2N548	15	4.	NPN T05
2N512B	15	20	PNP E503	2N549	15	20	NPN T05
2N513	15	20	PNP E503	2N550	15	20	NPN T05
2N513A	15	20	PNP E503	2N551	15	20	NPN T05
2N513B	15	20	PNP E503	2N552	15	20	NPN T05
2N514	15	20	PNP E503	2N553	2.0	40	PNP E501
2N514A	15	20	PNP E503	2N554	10	50	PNP T03
2N514B	15	20	PNP E503	2N555	20	50	PNP T03
2N515	50	7.5	NPN T022	2N556		50	NPN T05
2N516	50	7.5	NPN T022	2N557	10	30	NPN T05
2N517	50	7.5	NPN T022	2N558	10	75	NPN T05
2N518	6.0	60	PNP 8222	USA 2N559 1	3.0	25	PNP T028
2N519	2.0	25	PNP T05	USA 2N559 2	3.0	25	PNP T028
2N519A	25	35	PNP T05	USA 2N559 3	3.0	25	PNP T028
2N520	25	40	PNP T05	2N560	.10	20	NPN T029

TYPE NO.	I _{CBO} (μ A)	h _{fe}	PNP-DWG. NPN NO.	TYPE NO.	I _{CBO} (μ A)	h _{fe}	PNP-DWG. NPN NO.
JAN 2N560	10	20	NPN T029	2N629	20	10	PNP T03
2N561	30	20	PNP T03	2N630	20	10	PNP T03
2N563	25	25	PNP	2N631	25	200	PNP T05
2N564	25	25	PNP T05	2N632	25	120	PNP T05
2N565	25	55	PNP	2N633	25	60	PNP T05
2N566	25	55	PNP T05	2N634	15	15	NPN T09
2N567	15	40	NPN	2N634A	60	15	NPN T05
2N568	25	100	PNP T05	2N635	15	25	NPN T09
2N569	25	150	PNP	2N636	15	35	NPN T09
2N570	25	150	PNP T05	2N636A	60	190	NPN T05
2N571	25	200	PNP	2N637	10	30	PNP T03
2N572	25	200	PNP T05	2N637A	10	30	PNP T03
2N573	40	150	PNP T05	2N637B	10	30	PNP T03
2N574	70	90	PNP F604	2N638	10	20	PNP T03
USA 2N574	70	90	PNP F604	2N638A	10	20	PNP T03
2N574A	20	90	PNP F604	2N638B	10	20	PNP T03
2N575	70	10	PNP F604	2N639	10	15	PNP T03
USA 2N575	70	10	PNP F604	2N639A	50	15	PNP T03
2N575A	20	10	PNP F604	2N639B	50	15	PNP T03
USA 2N575A	20	19	PNP F604	2N640	50	60	PNP T07
2N576	10	30	NPN T05	2N641	70	60	PNP T07
2N576A	40	30	NPN T05	2N642	70	60	PNP T07
2N578	20	15	PNP T09	2N643	10	45	PNP T09
2N579	20	30	PNP T09	2N644	10	45	PNP T09
2N580	20	45	PNP T09	2N645	10	45	PNP T09
2N581	20	30	PNP T05	2N647	14	70	NPN T01
2N582	20	60	PNP T05	2N647/22	14	70	NPN T022
2N583	20	30	PNP T01	2N649	14	65	NPN T01
2N584	20	60	PNP T01	2N649/22	14	65	NPN T022
2N585	80	40	PNP T09	2N650	50	49	PNP T05
2N586	16	55	PNP B219	2N650A	50	50	PNP T05
2N587	10	20	PNP T05	IN 2N650A	50	30	PNP T05
2N588	15		PNP T01	2N651	50	80	PNP T05
2N588A	15	30	PNP T01	2N651A	50	85	PNP T05
2N589	20	20	PNP T03	IN 2N651A	50	50	PNP T05
2N591	70	70	PNP T01	2N652	50	130	PNP T05
2N597	25	40	PNP T05	2N652A	50	160	PNP T05
2N598	25	50	PNP T05	IN 2N652A	50	100	PNP T05
USA 2N598	25	50	PNP T031	2N653	15	49	PNP T05
2N599	25	75	PNP T05	2N654	15	80	PNP T05
USN 2N599	25	70	PNP T09	2N655	15	130	PNP T05
USA 2N600	25	50	PNP T031	2N656	10	30	NPN T05
2N602	25	50	PNP T09	AN 2N656	10	30	NPN T05
2N602A	50	50	PNP T09	2N656A	10	60	NPN T05
2N603	25	65	PNP T09	2N657	10	30	NPN T05
2N603A	50	65	PNP T09	PN 2N657	10	30	NPN T05
2N604	25	90	PNP T09	2N657A	10	60	NPN T05
USAF 2N604	80	40	PNP T05	2N658	50	50	PNP T05
2N604A	50	80	PNP T09	2N659	50	70	PNP T05
2N609	25	90	PNP T05	2N660	50	90	PNP T05
2N610	25	65	PNP T05	2N661	50	120	PNP T05
2N611	15	45	PNP T05	2N662	50	70	PNP T05
2N612	25	25	PNP T05	2N663	12	25	PNP T03
2N613	25	35	PNP T05	2N665	20	40	PNP T03
2N617	60	15	PNP T05	IN 2N665	10	40	PNP T03
2N618	30	60	PNP T03	2N669	30	75	PNP T03
2N624	30	20	PNP B203	2N670	75	100	PNP B201
USA 2N624	30	20	PNP B203	2N677	20	20	PNP T03
2N627	20	10	PNP T03	2N677A	20	20	PNP T03
2N628	20	10	PNP T03	2N677B	50	20	PNP T03

TYPE NO.	I_{CBO} (μA)	h_{fe}	PNP-DWG. NPN NO.	TYPE NO.	I_{CBO} (μA)	h_{fe}	PNP-DWG. NPN NO.
2N677C	5.0	20	PNP T03	2N719A	.01	20	NPN T018
2N678	2.0	50	PNP T03	2N720	2.0	80	NPN T018
2N678A	2.0	50	PNP T03	2N720A	.01	40	NPN T018
2N678B	2.0	50	PNP T03	2N721	.0	20	PNP T018
2N678C	5.0	50	PNP T03	2N721A	.10	15	PNP T018
2N679	25	30	NPN B204	2N722	.0	30	PNP T018
2N680	14	35	PNP	2N722A	.10	30	PNP T018
USA 2N694	3.0	9*	PNP T028	2N725		20	PNP T018
2N695	3.0	40	PNP T017	2N726	.0	30	PNP T018
USN 2N695	100	25	PNP T017	2N727	.0	60	PNP T018
2N696	1.0	20	NPN T05	2N728	5.0	7.5	NPN T018
JAN 2N696	.50	20	NPN T05	2N729	5.0	7.5	NPN T018
2N697	1.0	40	NPN T05	2N730	100	40	NPN T018
JAN 2N697	.50	40	NPN T05	2N731	100	80	NPN T018
2N697A	.10	80	NPN T05	2N734	10	35	NPN T018
2N698	.005	.20	NPN T05	2N735A	5 N	40	NPN T018
2N699	2.0	40	NPN T05	2N736	10	80	NPN T018
2N699A	.10	80	NPN T05	2N736B	5 N	80	NPN T018
2N699B	.01	80	NPN T05	2N736A	10	140	NPN T018
2N700	2.0	10	PNP T017	2N738	10	35	NPN T018
2N700A	100	4*	PNP T017	2N739	10	70	NPN T018
2N700A/18	100	4*	PNP T018	2N739A	5 N	40	NPN T018
USA 2N700A	2.0	4*	PNP T017	2N740A	5 N	80	NPN T018
2N700/18	2.0	10	PNP T018	2N741	3.0	25	PNP T018
2N702	5.0	40	NPN T018	2N741A	3.0	25	PNP T018
USA 2N702	5.0	40	NPN T018	2N742	10	20	NPN T018
2N703	5.0	70	NPN T018	2N742A	10	20	NPN T018
USA 2N703	5.0	70	NPN T018	2N743		40	NPN T018
2N705	100	40	PNP T018	2N743/46		40	NPN T046
JAN 2N705	3.0	25	PNP T018	2N743/51		40	NPN T051
2N705A		40	PNP T018	2N744		80	NPN T018
2N706	.05	20	NPN T018	USN 2N744		120	NPN T018
JAN 2N706	.10	30	NPN T018	2N744/46		80	NPN T046
2N706A	10	20	NPN T018	2N744/51		80	NPN T051
2N706A/TNT	.05	20	NPN HB12	2N752	.10	40	NPN T018
2N706A/TPT	.05	20	NPN G724	2N753	10	80	NPN T018
2N706A/46	10	20	NPN T046	2N753/46	.50	40	NPN T046
2N706A/51	10	20	NPN T046	2N753/51	.50	40	NPN T051
2N706B	10	40	NPN T018	2N754	1.0	40	NPN T018
2N706B/46	10	40	NPN T046	2N755	1.0	40	NPN T018
2N706B/51	10	40	NPN T051	2N756	50	18	NPN T018
2N706C		20	NPN T018	2N756A	50	19	NPN T018
2N706C/46	1.0	20	NPN T046	2N757	50	30	NPN T018
2N706C/51	1.0	20	NPN T051	2N757A	50	29	NPN T018
2N706/51	.05	20	NPN T051	USA 2N757A	50	18	NPN T018
2N706/KVT	.05	20	NPN G723	2N758	50	54	NPN T018
2N706/TNT	.05	20	NPN HB12	2N758A	.10	54	NPN T018
2N706/46	.05	20	NPN T046	2N758B	5 N	18	NPN T018
2N706/TPT	.05	20	NPN G724	2N759	50	63	NPN T018
2N707	5.0	14	NPN T018	2N759A	50	63	NPN T018
2N707A	10	30	NPN T018	USA 2N759A	50	35	NPN T018
2N708	.025	30	NPN T018	2N759B	5 N	36	NPN T018
2N715	10	30	NPN T018	2N760	50	204	NPN T018
USA 2N716	10	10	NPN T018	2N760A	50	204	NPN T018
2N717	1.0	20	NPN T018	USA 2N760A	50	76	NPN T018
2N717A			NPN T018	2N760B	5 N	76	NPN T018
2N718	1.0	40	NPN T018	2N761	50	19	NPN T018
2N718A	.01	40	NPN T018	2N762	50	39	NPN T018
USN 2N718A	10	35	NPN T018	2N768	10	40	PNP T018
2N719	2.0	20	NPN T018	2N769	10	55	PNP T018

TYPE NO.	I _{CBO} (mA)	h _{FE}	PNP- DWG. NPN NO.	TYPE NO.	I _{CBO} (μA)	h _{FE}	PNP- DWG. NPN NO.
2N79A	25	85	PNP T018	2N911	.025	65	NPN T018
2N780	.01	20	NPN T018	USA 2N911	.025	76	NPN T018
2N781	3.0	25	PNP T018	2N912	.025	38	NPN T018
2N782	3.0	20	PNP T018	USA 2N912	.025	20	NPN T018
2N783	.25	50	NPN T018	2N913	.05	75	NPN T018
2N784	.25	25	NPN T018	2N914	25 N	55	NPN T018
2N784A	100	88	NPN T018	2N914/46	.025	39	NPN T046
2N784A/46	100	88	NPN T046	2N914/51	.025	30	NPN T051
2N784A/51	100	88	NPN T051	2N915	.01	50	NPN T018
2N794	3.0	50	PNP T018	2N916	.01	40	NPN T018
2N795	3.0	50	PNP T018	USA 2N916	10 N	40	NPN T018
2N796	3.0	75	PNP T018	2N917	.001	20	NPN 8225
2N797	100	85	NPN T018	2N917/46	.001	20	NPN
2N827		100	PNP T018	2N917/51	.001	20	NPN T051
2N828	100	40	PNP T018	2N918	.01	20	NPN 8225
2N828A	3.0	40	PNP T018	2N918/46	.01	20	NPN T046
2N829	3.0	80	PNP T018	2N918/51	.01	20	NPN T051
2N834	.50	40	NPN T018	2N919	10	4.	NPN T018
2N834A		25	NPN T018	2N920	10	4.	NPN T018
2N834/46	.50	40	NPN T046	2N921	10	4.	NPN T018
2N834/51	.50	40	NPN T05	2N922	10	4.	NPN T018
2N838	.50	40	NPN T018	2N923	50	21	PNP T018
2N838/46	.50	40	NPN T046	2N924	50	47	PNP T018
2N838/51	.50	40	NPN T051	2N925	50	17	PNP T018
2N837	3.0	30	PNP T018	2N926	50	38	PNP T018
2N838		30	PNP T018	2N927	50	15	PNP T018
2N839	1.0	35	NPN T018	2N928	50	34	PNP T018
2N840	1.0	70	NPN T018	2N929	10	60	NPN T018
2N841	1.0	140	NPN T018	JAN 2N929	2	60	NPN T018
2N841/46	1.0	140	NPN T046	USA 2N929	10	60	NPN T018
2N841/51	1.0	140	PNP T051	2N929A	2	60	NPN T018
2N841/KVT	1.0	140	NPN G723	2N929/51	10	60	NPN T051
2N841/TNT	1.0	140	NPN H812	2N930	10	150	NPN T018
2N841/TPT	1.0	140	NPN G724	JAN 2N930	2	150	NPN T018
2N842	1.0	20	NPN T018	USA 2N930	10	150	NPN T018
2N843	1.0	40	NPN T018	2N930A	2	150	NPN T018
2N844	1.0	80	NPN T018	2N930A/46	2	150	NPN T046
2N845	1.0	80	NPN T018	2N930A/51	2	150	NPN T051
2N846A	3.0	35	PNP T018	2N930/KVT	10	150	NPN G723
2N849	10	40	NPN H804	2N930/TNT	10	150	NPN H812
2N850	10	80	NPN H804	2N930/TPT	10	150	NPN G724
2N851	10	40	NPN T050	2N930/46	10	150	NPN T046
2N852	10	80	NPN T050	2N930/51	10	150	NPN T051
USA 2N852		60	NPN T050	2N934	6.0	60	PNP T018
2N858	1.0	20	PNP T018	2N935	.10	11	PNP T018
2N859	1.0	35	PNP T018	2N936	.10	28	PNP T018
2N860	1.0	20	PNP T018	2N937	.10	60	PNP T018.
2N861	1.0	38	PNP T018	2N938	.025	15	PNP T018
2N862	.01	20	PNP T018	2N939	.025	30	PNP T018
2N863	1.0	35	PNP T018	2N940	.025	60	PNP T018
2N864	.10	35	PNP T018	2N941	2.5	50	PNP T018
2N865	.10	75	PNP T018	2N942	2.5	50	PNP T018
2N869	.01	20	PNP T018	2N943			PNP T018
2N869A	.01	40	PNP T018	2N944			PNP T018
USA 2N869A	.01	40	PNP T018	2N945			PNP T018
2N870	.01	75	NPN T018	2N946			PNP T018
2N871	.01	130	NPN T018	2N947	1.0	30	NPN T018
2N909	1.0	110	NPN T018	2N955	5.0	60	NPN T018
2N910	.025	125	NPN T018	2N955A	5.0	50	NPN T018
USA 2N910	.025	80	NPN T018	2N956		100	NPN T018

TYPE NO.	I _{CBO} (μ A)	h _{fe}	PNP- DWG. NPN NO.	TYPE NO.	I _{CBO} (μ A)	h _{fe}	PNP- DWG. NPN NO.
2N957	5.0	45	NPN T018	2N1015D	10	10	NPN F601
2N960	3.0	40	PNP T018	2N1015E	10	10	NPN F601
2N960/46	3.0	40	PNP T046	2N1016	10	10	NPN F601
2N961	3.0	40	PNP T018	2N1016A	10	10	NPN F601
2N961/46	3.0	40	PNP T046	2N1016B	10	10	NPN F601
2N962	3.0	40	PNP T018	USN 2N1016B	1.0	10	NPN F601
USN 2N962	3.0	40	PNP T018	2N1016C	10	10	NPN F601
2N962/46	3.0	40	PNP T046	USN 2N1016C	1.0	10	NPN F601
2N963	5.0	20	PNP T018	2N1016D	10	10	NPN F601
2N964	3.0	70	PNP T018	USN 2N1016D	1.0	10	NPN F601
USN 2N964	3.0	70	PNP T018	2N1016E	10	10	NPN F601
2N964A	3.0	80	PNP T018	2N1017	25	100	PNP T05
2N964/46	3.0	70	PNP T046	2N1018	4.0	140	PNP T05
2N965	3.0	70	PNP T018	2N1021	2.0	30	PNP T03
2N966	3.0	70	PNP T018	USA 2N1021	.50	30	PNP E504A
2N967	5.0	40	PNP T018	2N1021A	.50	30	PNP T03
2N968	3.0	20	PNP T018	2N1022	2.0	30	PNP T03
2N969	3.0	20	PNP T018	USA 2N1022	.50	30	PNP E504A
2N970	3.0	20	PNP T018	2N1022A	.50	30	PNP T03
2N971	10	20	PNP T018	2N1023	12	60	PNP T044
2N972	3.0	40	PNP T018	2N1024	.025	15	PNP T05
2N973	3.0	40	PNP T018	2N1025	.025	15	PNP T05
2N974	3.0	40	PNP T018	JAN 2N1025	100	9.	PNP T05
2N975	10	40	PNP T018	2N1026	.025	30	PNP T05
2N976	100	80	PNP T018	JAN 2N1026	100	18	PNP T05
2N978	5.0	38	PNP T018	2N1026A	.025	36	PNP T05
2N979	3.0	50	PNP T018	2N1027	.025	30	PNP T05
2N980	5.0	50	PNP T018	2N1028	.025	9.	PNP T05
2N981	1.0	36	PNP T018	2N1029	15	20	PNP E511
2N982	3.0	100	PNP T018	2N1029A	15	20	PNP E511
2N983	3.0	85	PNP T018	2N1029B	15	20	PNP E511
2N984	5.0	70	PNP T018	2N1029C	15	20	PNP E511
2N985	100	60	PNP T018	2N1030	15	50	PNP E511
2N987	8.0	100	PNP B225	2N1030A	15	50	PNP E511
USA 2N987	8.0	100	PNP B225	2N1030B	15	50	PNP E511
2N988	.50	20	NPN T018	2N1030C	15	50	PNP E511
2N989	.50	20	NPN T018	2N1031	15	20	PNP T041
2N990	8.0	150	PNP T018	2N1031A	15	20	PNP T041
2N991	8.0	40	PNP B225	2N1031B	15	20	PNP T041
2N992	8.0	40	PNP B225	2N1031C	15	20	PNP T041
2N993	8.0	150	PNP T018	2N1032	15	50	PNP T041
2N995	.005	35	PNP T018	2N1032A	15	50	PNP T041
2N995A	5 N	35	PNP T018	2N1032B	15	50	PNP T041
2N996	5 N	75	PNP T018	2N1032C	15	50	PNP T041
2N997	10 N	1000	PNP T018	2N1034	1.0	15	PNP T05
2N1000	15	35	NPN T05	2N1035	1.0	30	PNP T05
2N1007	1.0	30	PNP T03	2N1036	1.0	60	PNP T05
2N1008		90	PNP T05	2N1037	1.0	25	PNP T05
2N1008A		90	PNP T05	2N1038	125	20	PNP B243
2N1008B		90	PNP T05	2N1038-1	.65	20	PNP F646
USA 2N1008B		90	PNP T05	2N1038-2	.65	20	PNP F603A
2N1009				2N1038-2	.65	20	PNP F622
2N1010	10	35	NPN T01	2N1039	125	20	PNP B243
2N1011	20	30	PNP T03	JAN 2N1039	70	20	PNP T085
USA 2N1011	15	30	PNP T03	2N1039-1	.65	20	PNP F646
2N1012	25	40*	NPN T05	2N1039-2	.65	20	PNP F603A
2N1015	10	10	NPN F601	2N1039-2	.65	20	PNP F622
2N1015A	10	10	NPN F601	2N1040	125	20	PNP B243
2N1015B	10	10	NPN F601	2N1040-1	.65	20	PNP F646
2N1015C	10	10	NPN F601	2N1040-2	.65	20	PNP F603A

TYPE NO.	I _{CBO} (μA)	h _{fe}	PNP- DWG. NPN NO.	TYPE NO.	I _{CBO} (μA)	h _{fe}	PNP- DWG. NPN NO.
2N1040-2	.65	20	PNP F622	2N1067	.50	15	NPN T08
2N1041	125	20	PNP 6243	2N1068	.50	15	NPN T08
JAN 2N1041	70	20	PNP T085	2N1069	1.0	10	NPN T03
2N1041-1	.65	20	PNP F646	2N1070	1.0	10	NPN T03
2N1041-2	.65	20	PNP F603A	USA 2N1072	.10	20	NPN T03B
2N1041-2	.65	20	PNP F622	2N1073	1.0	20	PNP T03
2N1042	.65	20	PNP F603A	2N1073A	1.0	20	PNP T03
2N1042	.65	20	PNP F622	2N1073B	2.0	20	PNP T03
JAN 2N1042	8.0	20	PNP F624	2N1079	10	20	NPN T053
2N1042-1	.65	20	PNP F646	2N1080	10	20	NPN T053
2N1042-2	.65	20	PNP T05	2N1081	15	20	NPN T05
2N1042-2	.65	20	PNP F603A	USA 2N1081	.50	20	NPN T05
2N1043	.65	20	PNP F603A	2N1082	.50	10	NPN T05
2N1043	.65	20	PNP F622	USA 2N1082	.50	10	NPN T05
JAN 2N1043	8.0	20	PNP F624	2N1084	10	20	PNP T05
2N1043-1	.65	20	PNP F646	2N1085	50	40	NPN T05
2N1043-2	.65	20	PNP T05	2N1086	3.0	40	NPN A104
2N1043-2	.65	20	PNP F603A	2N1086A	3.0	40	NPN A104
2N1044	.65	20	PNP F603A	2N1087	3.0	40	NPN A104
2N1044	.65	20	PNP F622	2N1090	25	50	NPN T09
JAN 2N1044	8.0	20	PNP F624	2N1091	25	70	NPN T09
2N1044-1	.65	20	PNP F646	2N1092	.50	15	NPN T05
2N1044-2	.65	20	PNP T05	2N1093	6.0	125	PNP
2N1044-2	.65	20	PNP F603A	USA 2N1094	5.0	50	PNP T02B
2N1045	.65	20	PNP F603A	2N1097	16	34	PNP T05
2N1045	.65	20	PNP F622	2N1098	16	34	PNP T05
JAN 2N1045	8.0	20	PNP F624	2N1099	4.0	35	PNP T036
2N1045-1	.65	20	PNP HT51	2N1100	4.0	25	PNP T036
2N1045-2	.65	20	PNP A22	2N1101	50	45	NPN T022
2N1046	2.0	40	PNP T03	2N1102	50	45	NPN T022
USN 2N1046	10	40	PNP T03	2N1103	1.0	30	NPN T05
2N1046A	2.0	40	PNP T03	2N1104	1.0	45	NPN T05
2N1046B	2.0	20	PNP T03	2N1107	10	34	PNP T022
2N1047	.015	12	NPN F603	2N1108	10	33	PNP T022
2N1047A	.015	12	NPN F603	2N1109	10	20	PNP T022
USN 2N1047A	15	12	NPN F603	2N1110	10	29	PNP T022
2N1047B	.015	12	NPN F603	2N1111A	10	25	PNP T022
2N1048	.015	12	NPN F603	2N1111R	10	25	PNP T022
2N1048A	.015	12	NPN F603	2N1114	30	110	NPN T05
USN 2N1048A	15	12	NPN F603	2N1115	6.0		PNP A104
2N1049	.015	30	NPN F603	2N1116	15	60	NPN T05
2N1049A	.015	30	NPN F603	2N1117	15	40	NPN T05
USN 2N1049A	15	36	NPN F603	2N1118	1.0	30	PNP T05
2N1049B	.015	30	NPN F603	JAN 2N1118	.10	15	PNP T05
2N1050	.015	30	NPN F603	2N1118A	1.0	25	PNP T05
2N1050A	.015	30	NPN F603	2N1119	.10	25	PNP T05
USN 2N1050A	15	36	NPN F603	JAN 2N1119	.10	15	PNP T05
2N1050B	.015	30	NPN F603	2N1120	15	20	PNP T041
2N1051	.10	40	NPN T029	USA 2N1120	15	20	PNP T041
USN 2N1051	.10	30	NPN T029	2N1121	5.0	34	NPN A104
2N1052	10	35	NPN T05	2N1122	5.0	25	PNP T024
2N1053	10	35	NPN T05	2N1122A	5.0	25	PNP T024
2N1054	5.0	12	NPN T05	2N1124	75	125	PNP 8201
2N1055	15	30	NPN T05	2N1125	75	125	PNP 8201
2N1056	25	32	PNP T05	2N1126	20	120	PNP 8201
2N1057	16	58	PNP 8222	2N1129	25	165	PNP 8201
2N1058	50	17	NPN T022	2N1130	25	110	PNP 8201
2N1059	50	75	NPN T022	2N1131	1.0	20	PNP T05
2N1063	50	50	PNP T09	USN 2N1131	10	15	PNP T05
2N1066	12	60	PNP T033	2N1131A	50	20	PNP T05

TYPE NO.	I _{CBO} (μ A)	h _{fe}	PNP- DWG. NPN NO	TYPE NO.	I _{CBO} (μ A)	h _{fe}	PNP- DWG. NPN NO.
2N1131A/51	.50	20	PNP T051	2N1164	15	15	PNP T03
2N1131/51	1.0	20	PNP T051	2N1164A	15	15	PNP T03
2N1132	1.0	30	PNP T05	2N1165	15	15	PNP T041
USN 2N1132	10	25	PNP T05	USN 2N1165	15	15	PNP T041
2N1132A	.50	30	PNP T05	2N1165A	15	15	PNP T041
2N1132A/46	1.0	30	PNP T046	2N1166	15	15	PNP T03
2N1132A/51	1.0	30	PNP T051	2N1166A	15	15	PNP T03
2N1132B	100	60	PNP T05	2N1167	15	15	PNP T041
2N1132B/46	100	60	PNP T046	2N1167A	15	15	PNP T041
2N1132B/51	.01	30	PNP T051	2N1168	8.0	70	PNP T03
2N1132/KVT	.0	30	PNP G723	2N1171	5.0	30	PNP T05
2N1132/TNT	.0	30	PNP M812	USN 2N1173	10	50	NPN T05
2N1132/TPT	.0	30	PNP G724	USN 2N1174	10	50	PNP T05
2N1132/46	.0	30	PNP T046	2N1175	12	80	PNP T05
2N1132/51	.0	30	PNP T051	2N1175A	12	80	PNP T05
2N1136	.0	50	PNP T03	2N1176	25	40	PNP T05
2N1136A	.0	50	PNP T03	2N1176A	30	40	PNP T05
2N1136B	.0	50	PNP T03	2N1176B	35	40	PNP T05
2N1137	.0	75	PNP T03	2N1177	12	100	PNP T045
2N1137A	.0	75	PNP T03	2N1178	12	40	PNP T045
2N1137B	.0	75	PNP T03	2N1179	12	80	PNP T045
2N1138		100	PNP T03	2N1180	12	80	PNP T045
2N1138A		100	PNP T03	2N1183		20	PNP T08
2N1138B		100	PNP T03	USA 2N1183	.25	20	PNP T08
2N1139	5.0	40	NPN T05	2N1183A		20	PNP T08
2N1141	100	49	PNP T05	USA 2N1183A	.25	20	PNP T08
2N1141A		15	PNP T05	2N1183B		20	PNP T08
2N1142	100	49	PNP T05	USA 2N1183B	.25	20	PNP T08
USN 2N1142	100	10	PNP T05	2N1184		40	PNP T08
2N1142A		15	PNP T05	USA 2N1184	.25	40	PNP T08
2N1143	100	49	PNP T05	2N1184A		40	PNP T08
2N1143A		15	PNP T05	USA 2N1184A	.25	40	PNP T08
2N1144	16	55	PNP B222	2N1184B		40	PNP T08
2N1145	16	45	PNP B222	USA 2N1184B	.25	40	PNP T08
2N1146	4.0	60	PNP T03	2N1185	50	260	PNP T05
2N1146A	4.0	60	PNP T03	2N1186	50	49	PNP T05
2N1146B	4.0	60	PNP T03	2N1187	50	80	PNP T05
2N1146C	4.0	60	PNP T03	2N1188	50	130	PNP T05
2N1147	4.0	60	PNP T041	2N1189	50	120	PNP T05
2N1147A	4.0	60	PNP T041	2N1190	50	190	PNP T05
2N1147B	4.0	60	PNP T041	2N1191	15	40	PNP T05
2N1147C	4.0	60	PNP T041	2N1192	15	75	PNP T05
2N1149	2.0	13	NPN A107	2N1193	15	160	PNP T05
2N1150	2.0	24	NPN A107	2N1194	15	280	PNP T05
2N1151	2.0	39	NPN A107	2N1195		40	PNP T029
2N1152	2.0	49	NPN A107	JAN 2N1195	100	25	PNP T029
2N1153	2.0	99	NPN A107	2N1196	.25	10	PNP T05
2N1154	5.0	19	NPN A107	USA 2N1196	.25	10	PNP T05
2N1155	6.0	19	NPN A107	2N1197	.25	10	PNP T05
2N1156	8.0	15	NPN A107	2N1198		17	NPN
2N1157	7.0	10	PNP F604	USA 2N1199A	5.0	12	NPN B233
2N1157A	20	10	PNP F604	USA 2N1200	5.0	9.	NPN B233
USA 2N1157A	20	38	PNP F604	USA 2N1201	5.0	9.	NPN B233
USA 2N1158A	5.0	50	PNP T09	2N1202	2.0	40	PNP F632
2N1159	8.0	30	PNP T03	2N1203	2.0	25	PNP F632
2N1160	8.0	20	PNP T03	2N1204	7.0	30	PNP T09
2N1162	15	15	PNP T03	2N1205	5.0	10	NPN T05
2N1162A	15	15	PNP T03	2N1206	1.0	35	NPN T05
2N1163	15	15	PNP T041	2N1207	1.0	35	NPN T05
2N1163A	15	15	PNP T041	2N1208	10	15	NPN F607

TYPE NO.	I _{CBO} (μ A)	h _{fe}	PNP- DWG. NPN NO.	TYPE NO.-	I _{CBO} (μ A)	h _{fe}	PNP- DWG. NPN NO.
2N1208/1		15	NPN F607	2N1276		14	NPN T05
2N1209	20	20	NPN F607	2N1277	1.0	33	NPN T05
2N1209/1		20	NPN F607	2N1278	1.0	66	NPN T05
2N1210	10	15	NPN C302	2N1279	1.0	333	NPN T05
2N1210/1	20	15	NPN C302	2N1280	10	60	PNP T05
2N1211	10	15	NPN C302	2N1281	10	90	PNP T05
2N1211/1	10	15	NPN C302	2N1282	10	100	PNP T05
2N1212	10	12	NPN F607	2N1284	6.0	90	PNP T05
2N1212/1	10	12	NPN F607	2N1285	20	100	PNP T033
2N1217	1.5	60	NPN A154	2N1291	1.5	30	PNP T03
2N1218	.10	30	NPN T03	2N1292	1.0	30	NPN T03
2N1219	.10	18	PNP T05	2N1293	2.0	30	PNP T03
2N1220	10	9.	PNP T05	2N1294	2.0	30	NPN T03
2N1221	.10	18	PNP T05	2N1295	2.0	40	PNP T03
2N1222	.10	9.	PNP T05	2N1296	3.0	30	NPN T03
2N1223	.10	6.	PNP T05	2N1297	4.0	30	PNP T03
2N1224	12	60	PNP T033	2N1299		110	NPN T05
USA 2N1224	50	20	PNP T05	2N1300	3.0	50	PNP T05
2N1225	12	60	PNP T033	2N1301	3.0	75	PNP T05
USA 2N1225	50	20	PNP T05	2N1302	6.0	20	NPN T05
2N1226	12	60	PNP T033	JAN 2N1302	6.0	20	NPN T05
2N1227	1.0	50	PNP T03	2N1303	6.0	20	PNP T05
2N1228	.10	14	PNP T05	JAN 2N1303	6.0	20	PNP T05
2N1229	.10	30	PNP T05	2N1304	6.0	40	NPN T05
2N1230	.10	14	PNP T05	JAN 2N1304	6.0	40	NPN T05
2N1231	.10	30	PNP T05	2N1305	6.0	40	PNP T05
2N1232	.10	14	PNP T05	JAN 2N1305	6.0	40	PNP T05
2N1233	.10	30	PNP T05	2N1306	6.0	60	NPN T05
2N1234	.10	14	PNP T05	JAN 2N1306	6.0	60	NPN T05
USA 2N1234	100	14	PNP T05	2N1307	6.0	60	PNP T05
2N1236	.10	14	PNP G701	JAN 2N1307	6.0	60	PNP T05
2N1239	.10	30	PNP G701	2N1308	6.0	80	NPN T05
2N1240	.10	14	PNP G701	JAN 2N1308	6.0	80	NPN T05
2N1241	.10	30	PNP G701	2N1309	6.0	80	PNP T05
2N1242	.10	14	PNP G701	JAN 2N1309	6.0	80	PNP T05
2N1243	.10	30	PNP G701	2N1309A	6.0	80	PNP T05
2N1244	.10	14	PNP G701	2N1310	25	35	NPN T09
2N1247	.005	25	NPN T05	USN 2N1310	25	30	NPN T05
2N1248	.001	25	NPN T05	2N1311	25	30	NPN T09
2N1249		38	NPN T05	2N1312	25	40	NPN T09
2N1250		15	NPN C302	2N1313		83	PNP T05
2N1250/1	10	15	NPN C302	2N1314	.10	20	PNP E302
2N1251	50	150	NPN T022	2N1316	25	100	PNP T05
2N1252	10	35	NPN T05	2N1317	25	95	PNP T05
2N1253	10	45	NPN T05	2N1318	7.0	85	PNP T05
2N1254	.20	25	PNP T05	2N1319	6.0	30	PNP T05
2N1255	.20	40	PNP T05	2N1321	1.0	30	NPN T010
2N1256	.20	25	PNP T05	2N1323	2.0	30	NPN T010
2N1257	.20	40	PNP T05	2N1325	3.0	30	NPN T010
2N1258	.20	75	PNP T05	2N1326	2.0	30	PNP T010
2N1259	.20	25	PNP T05	2N1335	1.0	10	NPN T05
2N1261	2.0	20	PNP F632	2N1336	1.0	10	NPN T05
2N1262	2.0	30	PNP F632	2N1337	1.0	10	NPN T05
2N1263	2.0	45	PNP F632	2N1338	10	10	NPN T05
2N1264/13	50	25	PNP T013	2N1339	1.0	10	NPN T05
2N1265/5		75	PNP T05	2N1340	1.0	10	NPN T05
2N1266		46	PNP T022	2N1341	1.0	10	NPN T05
2N1273	14	27	PNP T05	2N1342	10	10	NPN T05
2N1274	14	27	PNP T05	2N1343	6.0	40	PNP T05
2N1275	1.0	15	PNP T05	2N1344	10	90	PNP T05

TYPE NO.	I _{CBO} (μ A)	h _{fe}	PNP-DWG NPN NO	TYPE NO.	I _{CBO} (μ A)	h _{fe}	PNP-DWG. NPN NO.
2N1345	6.0	60	PNP T05	2N1415	12	64	PNP T05
2N1346	5.0	125	PNP T05	2N1416			
2N1347	6.0	80	PNP T05	2N1417	10	60	NPN T05
2N1348	10	95	PNP	2N1418	1.0	60	NPN T05
2N1349	10	110	PNP	2N1420	1.0	150	NPN T05
2N1350	20	95	PNP	2N1420A	.01	100	NPN T05
2N1351	10	65	PNP	2N1425	12	50	PNP T07
2N1352	5.0	70	PNP T05	2N1426	12	130	PNP T07
2N1353	6.0	70	PNP T05	2N1427	5.0	120	PNP T024
2N1354	6.0	70	PNP T05	2N1428	.10	30	PNP T01
2N1355	6.0	80	PNP T05	2N1429	.10	30	PNP T05
2N1356	6.0	80	PNP T05	2N1430		30	PNP T041
2N1357	6.0	85	PNP T05	2N1431	50	112	NPN T022
2N1358	8.0	25	PNP T036	2N1432	15	60	PNP T033
JAN 2N1358	4.0	25	PNP T036	2N1437	2.0	20	PNP T013
2N1358A	10	25	PNP T036	2N1438	2.0	20	PNP T010
2N1359	3.0	35	PNP T03	2N1439	.025	9.	PNP T05
2N1360	3.0	60	PNP T03	2N1440	50	15	PNP T05
2N1362	3.0	35	PNP T03	2N1441	50	27	PNP T05
2N1363	3.0	60	PNP T03	2N1442	50	43	PNP T05
2N1364	3.0	35	PNP T03	2N1443	.025	65	PNP T05
2N1365	3.0	40	PNP T03	2N1446	10	35	PNP T05
2N1366	15	10	NPN T05	2N1447	10	52	PNP T05
2N1370	14	45	PNP T05	2N1448	10	70	PNP T05
2N1371	14	45	PNP T05	2N1449	10	95	PNP T05
2N1372	7.0	27	PNP T05	2N1450	100	20	PNP T09
2N1373	7.0	27	PNP T05	USAF 2N1450	10	20	PNP T05
2N1374	7.0	45	PNP T05	2N1451	15	45	PNP T05
2N1375	7.0	45	PNP T05	2N1452	15	60	PNP T05
2N1376	7.0	67	PNP T05	2N1465	2.5	20	PNP T013
2N1377	7.0	67	PNP T05	2N1466	2.5	20	PNP T010
2N1378	7.0	85	PNP T05	2N1469	.025	60	PNP T05
2N1379	7.0	85	PNP T05	JAN 2N1469	100	36	PNP T05
2N1380	14	27	PNP T05	2N1471	5.0	160	PNP
2N1381	14	27	PNP T05	2N1473	5.0	50	NPN T05
2N1382	14	45	PNP T05	2N1474	.05	26	PNP T05
2N1383	14	27	PNP T05	2N1474A	.05	30	PNP T05
2N1384	50	50	PNP T011	2N1475	.05	60	PNP T05
2N1385	10	10	PNP B277	2N1476	.20	24	PNP T05
2N1386	.10	45	NPN T05	2N1477	.20	45	PNP T05
2N1387	.10	30	NPN T05	2N1478	5.0	70	PNP T09
2N1388	.50		NPN T05	2N1479	.01	20	NPN T05
2N1389	.50		NPN T05	USA 2N1479	.01	20	NPN T05
2N1390	.80		NPN T05	2N1480	.01	20	NPN T05
2N1391	4.0	70	NPN T05	USA 2N1480	.01	20	NPN T05
2N1395	12	90	PNP T033	2N1481	.01	35	NPN T05
2N1396	12	90	PNP T033	USA 2N1481	.01	35	NPN T05
2N1397	12	90	PNP T033	2N1482	.01	35	NPN T05
2N1404	5.0	100	PNP T05	USA 2N1482	.01	35	NPN T05
2N1405	25	25	PNP T05	2N1483	.015	20	NPN T08
2N1409	10	45	NPN T05	USA 2N1483	.015	20	NPN T08
2N1409A	10	45	NPN T05	2N1484	.015	20	NPN T08
2N1410	10	90	NPN T05	USA 2N1484	.015	20	NPN T08
2N1410A	10	60	NPN T05	2N1485	.015	35	NPN T08
2N1411	5.0	75	PNP T025	USA 2N1485	.015	35	NPN T08
USA 2N1411	5.0	75	PNP T024	2N1487	.015	35	NPN T08
2N1412	4.0	25	PNP T036	USA 2N1487	.015	35	NPN T08
USA 2N1412	6.0	25	PNP T036	2N1488	.015	35	NPN T08
2N1413	12	30	PNP T05	USA 2N1488	.015	35	NPN T08
2N1414	12	44	PNP T05	2N1489	.025	25	NPN E504

TYPE NO.	I _{CBO} (μ A)	h _{FE}	PNP-DWG. NPN NO.	TYPE NO.	I _{CBO} (μ A)	h _{FE}	PNP-DWG. NPN NO.
USA 2N148Y	0.01	25	NPN F504A	2N1534A	2.0	35	PNP T03
2N1490	0.05	25	NPN F504	2N1535	2.0	35	PNP T03
USA 2N1493	0.05	25	NPN F504A	2N1535A	2.0	35	PNP T03
2N1491	10	50	NPN T039	2N1536	2.0	35	PNP T03
2N1492	10	50	NPN T039	2N1536A	2.0	35	PNP T03
2N1493	10	50	NPN T039	2N1537	2.0	35	PNP T03
USA 2N1493J	0.001	50	NPN T05	2N1537A	2.0	35	PNP T03
2N1494	100	30	PNP T031	2N1538	2.0	35	PNP T03
2N1494A	7.0	25	PNP T031	2N1539	2.0	50	PNP T03
2N1495	7.0	60	PNP T09	2N1539A	2.0	50	PNP T03
2N1496	7.0	60	PNP T031	2N1540	2.0	90	PNP T03
2N1499A	25	40	PNP T09	2N1540A	2.0	50	PNP T03
USA 2N1499A	25	50	PNP T09	2N1541	2.0	50	PNP T03
2N1499B	7.0	40	PNP T09	2N1541A	2.0	50	PNP T03
2N1500	25	70	PNP T09	2N1542	2.0	50	PNP T03
USA 2N1500	25	20	PNP T09	2N1542A	2.0	50	PNP T03
2N1500/18	1.5	70	PNP T018	2N1543	2.0	50	PNP T03
2N1501	2.0	25	PNP F632	2N1544	2.0	75	PNP T03
2N1502	2.0	25	PNP F632	2N1544A	2.0	75	PNP T03
2N1504/16	1.0	21	PNP T010	2N1545	2.0	75	PNP T03
2N1505	0.05	7.0	NPN T05	2N1545A	2.0	75	PNP T03
2N1506	0.01	10	NPN T05	2N1546	2.0	75	PNP T03
2N1506A	0.05U	10	NPN T05	2N1546A	2.0	75	PNP T03
USA 2N1506A	0.05U	10	NPN T05	2N1547	2.0	75	PNP T03
2N1507	100	150	NPN T05	2N1547A	2.0	75	PNP T03
2N1510	5.0	30	NPN A104	2N1548	2.0	75	PNP T03
2N1511	0.025	15	NPN T036	2N1549	3.0	10	PNP T03
USA 2N1511	0.025	15	NPN T036	2N1549A	3.0	10	PNP T03
2N1512	0.025	15	NPN T036	2N1550	3.0	10	PNP T03
USA 2N1512	0.025	15	NPN T036	2N1550A	3.0	10	PNP T03
2N1513	0.025	25	NPN T036	2N1551	3.0	10	PNP T03
USA 2N1513	0.025	25	NPN T036	2N1551A	3.0	10	PNP T03
2N1514	0.025	25	NPN T036	2N1552	3.0	10	PNP T03
USA 2N1514	0.025	25	NPN T036	2N1552A	3.0	10	PNP T03
2N1515	13	100	PNP T07	2N1553	3.0	30	PNP T03
2N1516	13	67	PNP T07	2N1553A	3.0	30	PNP T03
2N1517	13	67	PNP T07	2N1554	3.0	30	PNP T03
2N1519	4.0	15	PNP T036	2N1554A	3.0	30	PNP T03
2N1519	4.0	15	PNP T036	2N1555	3.0	30	PNP T03
2N1520	4.0	17	PNP T036	2N1555A	3.0	30	PNP T03
2N1521	4.0	17	PNP T036	2N1556	3.0	30	PNP T03
2N1522	4.0	22	PNP T036	2N1556A	3.0	30	PNP T03
2N1523	4.0	22	PNP T036	2N1557	3.0	50	PNP T03
2N1524	16	60	PNP T09	2N1557A	3.0	50	PNP T03
2N1524/33	16	60	PNP T033	2N1558	3.0	50	PNP T03
2N1525	16	60	PNP T09	2N1558A	3.0	50	PNP T03
2N1526	16	130	PNP T01	2N1559	3.0	50	PNP T03
2N1526/33	16	130	PNP T033	2N1559A	3.0	50	PNP T03
2N1527	16	130	PNP T040	2N1560	3.0	50	PNP T03
2N1528	1.0	4.0	NPN T05	2N1560A	3.0	50	PNP T03
2N1529	2.0	20	PNP T03	2N1561	10	10	PNP B249
2N1529A	2.0	20	PNP T03	2N1562	10	9.0	PNP B249
2N1530	2.0	20	PNP T03	2N1564	10	35	NPN T05
2N1530A	2.0	20	PNP T03	2N1565	10	70	NPN T05
2N1531	2.0	20	PNP T03	2N1566	10	140	NPN T05
2N1531A	2.0	20	PNP T03	2N1566A	10	140	NPN T05
2N1532	2.0	20	PNP T03	2N1572	10	35	NPN T05
2N1532A	2.0	20	PNP T03	2N1573	10	70	NPN T05
2N1533	2.0	20	PNP T03	2N1574	10	140	NPN T05
2N1534	2.0	15	PNP T03	2N1586	18	18	NPN A107

TYPE NO.	I _{CBO} (μ A)	h _{fe}	PNP - DWG. NPN NO.	TYPE NO.	I _{CBO} (μ A)	h _{fe}	PNP - DWG. NPN NO.
2N1587		18	NPN A107	2N1652	5.0	35	PNP T041
2N1588		18	NPN A107	USA 2N1652	5.0	35	PNP E521
2N1589		50	NPN A107	2N1653	5.0	35	PNP T041
2N1590		50	NPN A107	USA 2N1653	5.0	35	PNP E521
2N1591		50	NPN A107	2N1654	1.0	30	PNP T05
2N1592		140	NPN A107	2N1655	1.0	15	PNP T05
2N1593		140	NPN A107	2N1656	1.0	30	PNP T05
2N1594		140	NPN A107	2N1658	+50	30	PNP F615
2N1605	5.0	125	NPN T05	2N1659	+50	30	PNP F615
2N1605A	10	60	NPN T05	2N1666	+10	15	PNP E502
2N1613	+0.1	80	NPN T05	2N1667	+10		PNP E502
USN 2N1613	10	35	NPN T05	2N1668	+10		PNP E502
2N1613A	+0.02	80	NPN T05	2N1669	+10		PNP E502
2N1613/KVT	+0.1	80	NPN G723	2N1670	7.0	15	PNP T09
2N1613/TNT	+0.1	80	NPN H812	2N1672	25	50	NPN T05
2N1613/TPT	+0.1	80	NPN G724	2N1672A		20	NPN T05
2N1613/46	+0.1	80	NPN T046	2N1673	50	100	PNP T033
2N1613/S1	+0.1	80	NPN T051	2N1674	+50	50	NPN T05
2N1614	25	32	PNP B222	2N1676	+10	10.5	PNP T05
2N1615	2.0	25	NPN T05	2N1677	+10	50	PNP T05
2N1616	10	15	NPN F607	2N1678	25	25	PNP T09
2N1616A	1.0	15	NPN F607	2N1681	25	75	PNP T05
2N1616A/1	10	10	NPN F607	2N1683	3.0	85	PNP T05
2N1616/1	10	15	NPN F607	2N1690	+0.15	20	NPN F603
2N1617	10	15	NPN F607	2N1691	+0.15	20	NPN F603
2N1617A	1.0	15	NPN F607	2N1692	10	10	PNP F626
2N1617A/1	10	10	NPN F607	2N1693	10	9.	PNP F626
2N1617/1	10	15	NPN F607	2N1694	1.5	25	NPN T05
2N1618	10	15	NPN F607	2N1700	75	40	NPN T05
2N1618A	1.0	15	NPN F607	2N1701	100	20	NPN T08
2N1618A/	10	10	NPN F607	2N1702	200	15	NPN E504
2N1618/1	10	15	NPN F607	2N1703	200	15	NPN T036
2N1620	10	15	NPN F902	2N1704	+10	50	NPN T05
2N1620/1	10	15	NPN 1903	2N1705	10	110	PNP T05
2N1622	7.0	40	NPN T05	2N1706	10	90	PNP T05
2N1623	1.0	25	PNP T05	2N1707	15	95	PNP T05
2N1624	1.0	120	NPN T05	2N1708	+0.25	20	NPN T046
2N1631	16	80	PNP T09	2N1708A	+0.25	30	NPN T046
2N1632	16	80	PNP T09	2N1709	+0.1	7.5	NPN T08
2N1633	16	75	PNP T09	2N1710	+0.5	7.5	NPN T08
2N1634	16	75	PNP T09	2N1711	+0.1	130	NPN T05
2N1635	16	75	PNP T09	JSN 2N1711	10	100	NPN T05
2N1636	16	75	PNP T09	2N1711A	+0.02	200	NPN T05
2N1637	5.0	80	PNP T09	2N1711B	+0.02	50	NPN T05
2N1637/33	5.0	80	PNP T033	2N1711/KVT	+0.1	130	NPN G723
2N1638	7.0	75	PNP T01	2N1711/TNT	+0.1	130	NPN H812
2N1638/33	7.0	75	PNP T033	2N1711/TPT	+0.1	130	NPN G724
2N1639	7.0	75	PNP T09	2N1711/46	+0.1	130	NPN T046
2N1639/33	7.0	75	PNP T033	2N1711/S1	+0.1	130	NPN T051
2N1643	+0.01	18	PNP T05	2N1714	2.0	20	NPN T05
2N1644	1.0	75	NPN T05	USA 2N1714	2	20	NPN T05
2N1644A	1.0	75	NPN T05	2N1715	2.0	20	NPN T05
2N1646	100	20	PNP G71B	USA 2N1715	2	20	NPN T05
USAF2N1646	3.0	20	PNP G71B	2N1716	2.0	40	NPN T05
2N1647	+10	15	NPN F608	USA 2N1716	2	40	NPN T05
2N1648	+10	165	NPN F608	2N1717	2.0	40	NPN T05
2N1649	+10	30	NPN F608	USA 2N1717	2	40	NPN T05
2N1650	+10	30	NPN F608	2N1718	+0.5	20	PNP F609
2N1651	5.0	35	PNP T041	2N1719	+0.5	20	NPN F609
USA 2N1651	5.0	35	PNP E521	2N1720	+0.5		NPN F609

TYPE NO.	I _{CBO} (μ A)	h _{fe}	PNP- NPN	DWG. NO.	TYPE NO.	I _{CBO} (μ A)	h _{fe}	PNP- NPN	DWG. NO.
2N1721	.05	40	NPN	F609	2N1833	10	10	NPN	F613
2N1722	10	20	NPN	T053	2N1837	.50	9.	NPN	T05
JAN 2N1722	10	30	NPN	T053	2N1837A	.50	7.	NPN	T05
2N1722A	10	20	NPN	T053	2N1838	1.5	90	NPN	T05
2N1722/1	10	90	NPN	C303	2N1839	1.5	9.	NPN	T05
2N1723	10	50	NPN	T053	2N1840		12	NPN	T05
2N1724	10	20	NPN	F607	2N1853	4.2	30	PNP	T05
JAN 2N1724	10	30	NPN	F607	USN 2N1853	4.2	30	PNP	T05
2N1724A	10	20	NPN	F607	2N1853/1A	4.2	30	PNP	T018
2N1724/1	20	20	NPN	F307	2N1854	4.2	40	PNP	T05
2N1725	10	50	NPN	F607	USN 2N1854	25	25	PNP	T05
2N1726	10	50	PNP	T09	2N1864	10	10	PNP	T09
2N1727	10	20	PNP	T09	2N1865	10	70	PNP	T09
2N1728	10	40	PNP	T09	2N1866	10	70	PNP	T09
2N1742	10	33	PNP	T09	2N1867	10	50	PNP	T09
2N1743	10	33	PNP	T09	2N1868	10	33	PNP	T09
2N1744	10	33	PNP	T09	2N1886	.35	20	NPN	F608
2N1745	10	10	PNP	T09	2N1889	.01	75	NPN	T05
2N1746	10	60	PNP	T09	2N1890	.01	130	NPN	T05
2N1747	10	60	PNP	T09	USN 2N1890	10	300	NPN	T05
2N1748	10	30	PNP	T09	2N1891	5.0	25	NPN	T05
2N1748A	10	70	PNP	T09	2N1893	.01	40	NPN	T05
2N1749	100	45	PNP	T09	USN 2N1893	10	45	NPN	T05
2N1751	5.0	30	PNP	T03	2N1893A	.01	30	NPN	T05
2N1752	10	30	PNP	T09	2N1893/KVT	.01	83	NPN	G723
2N1754	100	50	PNP	T09	2N1893/TNT	.01	90	NPN	HB12
2N1755	3.0	30	PNP	C307	2N1893/TPY	.01	AC	NPN	G724
2N1756	3.0	30	PNP	C307	2N1893/46	.01	90	NPN	T046
2N1757	3.0	30	PNP	C307	2N1893/51	.01	AC	NPN	T051
2N1758	3.0	30	PNP	C307	2N1899	25	10	NPN	F635
2N1759	3.0	60	PNP	C307	2N1900	25	8.	NPN	F631
2N1760	3.0	60	PNP	C307	2N1901	25	20	NPN	F635
2N1761	3.0	60	PNP	C307	2N1902	25	10	NPN	F634
2N1762	2.0	60	PNP	C307	2N1903	25	5.	NPN	F635
2N1768	.015	35	NPN	F603	2N1904	25	20	NPN	F634
2N1769	.015	35	NPN	F603	2N1905	.50	50	PNP	T03
2N1785	10	40	PNP	T09	2N1906	.90	75	PNP	T03
2N1786	10	15	PNP	T09	2N1907	10	20	PNP	T03
2N1787	10	25	PNP	T09	2N1908	10	20	PNP	T03
2N1788	5.0	50	PNP	T09	2N1917	2.5N	50	PNP	T05
2N1789	7.0	20	PNP	T09	2N1918	2.5N	50	PNP	T05
2N1790	7.0	40	PNP	T09	2N1919			PNP	T05
2N1808	.50	125	NPN	T05	2N1920			PNP	T05
2N1809	10	10	NPN	F610	2N1921			PNP	T05
2N1810	10	10	NPN	F610	2N1922			PNP	T05
2N1811	10	10	NPN	F610	2N1924	10		PNP	T05
2N1812	10	10	NPN	F610	2N1925	10	64	PNP	T05
2N1813	10	10	NPN	F610	2N1926	10	80	PNP	T05
2N1814	10	10	NPN	F610	2N1936	10	10	NPN	F614
2N1816	10	14	NPN	F610	2N1937	10	10	NPN	F614
2N1817	10	14	NPN	F610	2N1940	.005	5.	PNP	F626
2N1818	10	14	NPN	F610	2N1943	10	12	NPN	T05
2N1819	10	14	NPN	F610	2N1944	1.0	300	NPN	T05
2N1823	10	10	NPN	F610	2N1945	1.0		NPN	T05
2N1824	10	10	NPN	F610	2N1946	1.0	300	NPN	T05
2N1825	10	10	NPN	F610	2N1947	1.0	650	NPN	T05
2N1826	10	10	NPN	F610	2N1948	1.0	650	NPN	T05
2N1830	10	10	NPN	F610	2N1949	1.0	650	NPN	T05
2N1831	10	10	NPN	F610	2N1950	1.0	375	NPN	T05
2N1832	10	10	NPN	F613	2N1951	1.0	375	NPN	T05

TYPE NO.	I _{CBO} (μ A)	h _{fe}	PNP- DWG NPN NO	TYPE NO.	I _{CBO} (μ A)	h _{fe}	PNP- DWG. NPN NO.
2N1952		375	NPN T05	2N2018	+10	20	NPN F608
2N1953	+70	15	NPN T05	2N2019	+10	20	NPN F608
2N1954	20	75	PNP T05	2N2020	+10	40	NPN F608
2N1955	20	125	PNP T05	2N2021	+10	40	NPN F608
2N1956	20	75	PNP T05	2N2032	20	20	NPN C302
2N1957	20	75	PNP T05	2N2032/1	2+0	20	NPN C303
2N1958	100	40	NPN T05	2N2033	+025	20	NPN T05
2N1958A	+20	15	NPN T05	2N2034	+025	20	NPN T05
2N1958/18	100	40	NPN T018	2N2035	+025	15	NPN T08
2N1959	100	80	NPN T05	2N2036	10	15	NPN T037
2N1959A	+20	25	NPN T05	2N2038	15	12	NPN T05
2N1959A/51	+20	25	NPN T051	2N2039	15	12	NPN T05
2N1959/18	100	80	NPN T018	2N2040	15	30	NPN T05
2N1960	100	25	PNP A1	2N2041	15	30	NPN T05
2N1960/46	100	25	PNP T046	2N2042	25	80	PNP T05
2N1961	100	20	PNP H801	2N2042A	25	80	PNP T05
2N1961/46	100	20	PNP T046	2N2043	25	180	PNP T05
2N1962	100	50	NPN H801	2N2043A	25	180	PNP T05
2N1962/46	100	50	NPN T046	2N2048	100	125	PNP T09
2N1963	100	25	NPN H801	2N2048A	25	40	PNP T09
2N1963/46	100	25	NPN T046	2N2049	+01	60	NPN T05
2N1964	100	40	NPN H801	2N2060			
2N1964/46	10	3+	NPN T046	USN 2N2060			
2N1965	100	80	NPN H801	2N2060A			
2N1965/46	100	80	NPN T046	2N2061	10	10	PNP T03
2N1969	25	125	PNP T05	2N2061A	2+0	20	PNP T03
2N1970	4+0	17	PNP T036	2N2062	10	20	PNP T03
2N1971	2+0	25	PNP E501	2N2062A	2+0	50	PNP T03
2N1972	1+0	110	NPN T05	2N2063	20	10	PNP T03
2N1973	+025	125	NPN T05	2N2063A	2+0	20	PNP T03
2N1974	+025	65	NPN T05	2N2064	20	20	PNPT03
2N1975	+025	38	NPN T05	2N2064A	2+0	50	PNP T03
2N1978	+1U	30	NPN F621	2N2065	20	10	PNP T03
2N1980	6+0	50	PNP T036	2N2065A	5+0	20	PNP T03
2N1981	6+0	50	PNP T036	2N2066	20	20	PNP T03
2N1982	6+0	50	PNP T036	2N2066A	5+0	50	PNP T03
2N1983	5+0	70	NPN T05	2N2067	3+0	20	PNP C307
2N1984	5+0	35	NPN T05	2N2067B	3+0	15	PNP C307
2N1985	5+0	15	NPN T05	2N2067G	3+0	25	PNP C307
2N1986	5+0	60	NPN T05	2N2067W	3+0	33	PNP C307
2N1987	5+0	20	NPN T05	2N2068	3+0	20	PNP C307
2N1988	5+0	35	NPN T05	2N2068G	3+0	25	PNP C307
2N1989	5+0	20	NPN T05	2N2068-0	3+0	20	PNP C307
2N1990		20	NPN T05	2N2075	4+0	20	PNP T036
2N1991	5+0	15	NPN T05	2N2075A	4+0	20	PNP T036
2N1993	10	50	NPN T05	2N2076	4+0	20	PNP T036
2N1997	25	70	PNP T05	2N2076A	4+0	20	PNP T036
2N1998	25	95	PNP T05	2N2077	4+0	20	PNP T036
2N1999	25	150	PNP T05	2N2077A	4+0	20	PNP T036
2N2000	100	175	PNP T05	2N2078	4+0	20	PNP T036
2N2001	100	60	PNP T05	2N2078A	4+0	20	PNP T036
2N2002	+001		PNP T05	2N2079	4+0	35	PNP T036
2N2003	+003		PNP T05	2N2079A	4+0	35	PNP T036
2N2004	50		PNP T05	2N2080	4+0	35	PNP T036
2N2005	50		PNP T05	2N2080A	4+0	35	PNP T036
2N2006	50		PNP T05	2N2081	4+0	35	PNP T036
2N2007	+005		PNP T05	2N2081A	4+0	35	PNPT036
2N2008	2+0	65	NPN T05	2N2082	4+0	35	PNP T036
2N2015	+05	15	NPN T036	2N2082A	4+0	35	PNP T036
2N2017	+01	35	NPN T05	2N2084	8+0	40	PNP T033

TYPE NO.	I _{CBO} (μ A)	h _{fe}	PNP- DWG. NPN NO.	TYPE NO.	I _{CBO} (μ A)	h _{fe}	PNP- DWG. NPN NO.
2N2084	50	40	PNP T033	2N2144A	2.0	50	PNP T03
2N2085	5.0	100	NPN T05	2N2145	2.0	50	PNP T03
2N2086	2.0	20	NPN T05	2N2145A	2.0	50	PNP T03
2N2087	100	65	NPN T05	2N2146	2.0	50	PNP T03
2N2089	8.0	150	PNP T07	2N2146A	2.0	50	PNP T03
2N2090	8.0	40	PNP T07	2N2147	1.0	100	PNP T03
2N2091	8.0	40	PNP T07	2N2148	1.0	40	PNP T03
2N2092	8.0	150	PNP T07	2N2150	.01	20	NPN F617
2N2094	.02	25	NPN T05	15A 2N2150	.50	20	NPN F617
2N2094A	.01	40	NPN T05	2N2151	.01	40	NPN F617
2N2095	15		PNP T031	15A 2N2151	.50	40	NPN F617
2N2095A	.01	100	NPN T05	2N2152	4.0	50	PNP T036
2N2096	12	40	PNP T031	2N2152A	4.0	50	PNP T036
2N2096A	.01	40	NPN T018	2N2153	4.0	50	PNP T036
2N2097	12	70	PNP T031	2N2153A	4.0	50	PNP T036
2N2097A	.01	100	NPN T018	2N2154	4.0	50	PNP T036
2N2098	15		PNP T09	2N2154A	4.0	50	PNP T036
2N2099	12	40	PNP T09	2N2155	4.0	50	PNP T036
2N2100	12	70	PNP T09	2N2155A	4.0	15	PNP T036
2N2101		15	NPN F607	2N2156	4.0	80	PNP T036
2N2102	.002	40	NPN T05	2N2156A	4.0	80	PNP T036
2N2102A	.002	40	NPN T05	2N2157	4.0	80	PNP T036
2N2104	.025	60	PNP T05	2N2157A	4.0	80	PNP T036
2N2105	.025	33	PNP T05	2N2158	4.0	80	PNP T036
2N2106	.20	12	NPN T05	2N2158A	4.0	80	PNP T036
2N2107		30	NPN T05	2N2159	4.0	80	PNP T036
2N2108		75	NPN T05	2N2159A	4.0	15	PNP T036
2N2109	10	10	NPN F613	2N2162	.01	35	PNP T05
2N2110	10	10	NPN F613	2N2163	.01	35	PNP T05
2N2111	10	10	NPN F613	2N2164	.02	40	PNP T05
2N2112	10	10	NPN F613	2N2165	.02	25	PNP T05
2N2113	10	10	NPN F613	2N2166	.02	25	PNP T05
2N2114	10	10	NPN F613	2N2167	.02	38	PNP T05
2N2116	10	10	NPN F613	2N2168	3.0	100	PNP T09
2N2117	10	10	NPN F613	2N2169	3.0	85	PNP T09
2N2118	10	10	NPN F613	2N2170	5.0	70	PNP T09
2N2119	10	10	NPN F613	2N2171	10	210	PNP T05
2N2123	10	10	NPN F613	2N2172	6.0	65	PNP T05
2N2124	10	10	NPN F613	2N2173	100	30	PNP T05
2N2125	10	10	NPN F613	2N2175	.001	50	PNP T05
2N2126	10	10	NPN F601	2N2176	.001	50	PNP T018
2N2130	10	10	NPN F613	2N2177		50	PNP T05
2N2131	10	10	NPN F613	2N2178	.001	50	PNP T018
2N2132	10	10	NPN F613	2N2185	1.0	10	PNP T018
2N2133	10	10	NPN F613	2N2186	1.0	10	PNP T018
2N2137	2.0	30	PNP T03	2N2187	1.0	10	PNP T018
2N2137A	2.0	30	PNP T03	2N2188	50	90	PNP 8228
2N2138	2.0	30	PNP T03	2N2189	50	135	PNP 8228
2N2138A	2.0	30	PNP T03	2N2190	50	90	PNP 8228
2N2139	2.0	30	PNP T03	2N2191	50	135	PNP 8228
2N2139A	2.0	30	PNP T03	2N2192	.01	150	NPN T05
2N2140	2.0	30	PNP T03	2N2192A	.01	150	NPN T05
2N2140A	2.0	30	PNP T03	2N2192B	.01	75	NPN T05
2N2141	2.0	30	PNP T03	2N2193	.01	80	NPN T05
2N2141A	2.0	30	PNP T03	2N2193A	.01	80	NPN T05
2N2142	2.0	50	PNP T03	2N2193B	.01	30	NPN T05
2N2142A	2.0	40	PNP T03	2N2194	.01	40	NPN T05
2N2143	2.0	50	PNP T03	2N2194A	.01	40	NPN T05
2N2143A	2.0	50	PNP T03	2N2194B	.01	40	NPN T05
2N2144	2.0	40	PNP T03	2N2195		20	NPN T05

TYPE NO.	I _{CBO}	h _{fe}	PNP - DWG. NPN NO.	TYPE NO.	I _{CBO} (μ A)	h _{fe}	PNP - DWG. NPN NO.
2N2195A	.01	20	NPN T05	2N2247	.01	10	NPN T018
2N2195B	.01	20	NPN T05	2N2248	.01	20	NPN T018
2N2196	.75	30	NPN MD14	2N2249	.01	40	NPN T018
2N2197	.75	75	NPN MD14	2N2250	.01	10	NPN T018
2N2198	.15	45	NPN T05	2N2251	.01	20	NPN T018
2N2201		30	NPN E509	2N2252	.01	40	NPN T018
2N2202	.05	30	NPN B229	2N2253	.01	10	NPN T018
2N2203	.05	30	NPN B230	2N2254	.01	20	NPN T018
2N2204	.05	30	NPN F615	2N2255	.01	40	NPN T018
2N2205	.025	20	NPN T018	2N2256	10	30	NPN T018
2N2206	.025	90	NPN T046	2N2257	10	50	NPN T018
2N2207		200	PNP T07	2N2258	10	30	NPN T018
2N2210	4.0	25	PNP T036	2N2259	10	50	PNP T018
USA 2N2210	4.0	25	PNP T036	2N2266	2.0	25	PNP F632
2N2212	2.0	50	PNP T041	2N2267	2.0	25	PNP F632
2N2216	.01	73	PNP T05	2N2268	2.0	25	PNP F632
2N2217	.01	40	NPN T05	2N2269	2.0	25	PNP F632
2N2217/51	.01	40	NPN T051	2N2270	.10	50	NPN T05
2N2218	.01	80	NPN T05	2N2271	500	75	PNP T05
USA 2N2218	.01	20	NPN T05	2N2273	100	20	PNP T018
2N2218A	.01	40	NPN T05	USA 2N2273	10	20	PNP T018
2N2218/TNT	.01	80	NPN H812	2N2274	3.0	10	PNP T018
2N2218/TPT	.01	80	NPN G724	2N2275	3.0	10	PNP T018
2N2218/51	.01	80	NPN T051	2N2276	3.0	10	PNP T018
2N2219	.01	150	NPN T05	2N2277	3.0	10	PNP T018
USA 2N2219	.01	30	NPN T05	2N2278	1.0	10	PNP T018
2N2219A	.01	100	NPN T05	2N2279	1.0	10	PNP T018
2N2219/TNT	.01	150	NPN H812	2N2280	3.0	10	PNP T018
2N2219/TPT	.01	150	NPN G724	2N2281	3.0	10	PNP T018
2N2219/51	.01	150	NPN T051	2N2282	.05	30	PNP T037
2N2220	.01	40	NPN T018	2N2283	.05	30	PNP T037
2N2221	.01	80	NPN T018	2N2284	.05	30	PNP T037
USA 2N2221	.01	40	NPN T018	2N2285	5.0	35	PNP T03
2N2221A	.01	20	NPN T018	2N2286	5.0	35	PNP T03
2N2222	.01	150	NPN T018	2N2287	5.0	35	PNP T03
USA 2N2222	.01	30	NPN T018	2N2288	1.0	20	PNP T03
2N2222A	.01	100	NPN T018	2N2289	1.0	20	PNP T03
2N2223				2N2290	2.0	20	PNP T03
2N2223A				2N2291	1.0	50	PNP T03
2N2226		100	NPN F601	2N2292	1.0	50	PNP T03
2N2227		100	NPN F601	2N2293	2.0	50	PNP T03
2N2228		100	NPN F601	2N2294	1.0	50	PNP T041
2N2229	10	100	NPN F601	2N2295	1.0	50	PNP T041
2N2230		400	NPN F601	2N2296	2.0	50	PNP T041
2N2231		400	NPN F601	2N2297	.01	40	PNP T05
2N2232		400	NPN F601	2N2297/51	.50	20	NPN T05
2N2233	10	400	NPN F601	2N2303	1.0	75	PNP T05
2N2234	1.0	15	NPN T03	2N2303/KVT	1.0	75	PNP G723
2N2235	1.0	40	NPN T03	2N2303/TNT	1.0	75	PNP H812
2N2236	.05	35	NPN T05	2N2303/TPT	1.0	75	PNP G724
2N2237	.05	65	NPN T05	2N2303/46	1.0	75	PNP T046
2N2239	10	50	NPN T037	2N2303/51	1.0	75	PNP T051
2N2240	.025	40	NPN T05	2N2304	.10	20	NPN T08
2N2241	.025	100	NPN T05	2N2305	.20	15	NPN T03
2N2242	.10	40	NPN T018	2N2308	.05	20	NPN T08
2N2243	.01	80	NPN T05	2N2309	.005	50	NPN T05
2N2243A	.01	80	NPN T05	2N2310	10	20	NPN T046
2N2244	.01	10	NPN T018	2N2311	10	20	NPN T046
2N2245	.01	20	NPN T018	2N2312	10	60	NPN T046
2N2246	.01	40	NPN T018	2N2313	10	60	NPN T046

TYPE NO.	I _{CBO} (μ A)	h _{fe}	PNP-DWG. NPN NO.	TYPE NO.	I _{CBO} (μ A)	h _{fe}	PNP-DWG. NPN NO.
2N2314	1.0	45	NPN T046	2N2394	1.0	20	PNP F607
2N2315	1.0	70	NPN T046	2N2397	+10	25	PNP T018
2N2316	100	70	NPN T05	2N2398	+01	150	NPN HB18
2N2317	+01	80	NPN T046	2N2399	+01	35	NPN HB18
2N2318	1.0	40	NPN T018	2N2390	+01	70	NPN HB18
2N2319	1.0	40	NPN T046	2N2393	1.0	15	PNP HB18
2N2320	1.0	40	NPN T05	2N2394	1.0	25	PNP HB18
2N2330	+10	80	NPN T05	2N2395	+01	20	NPN HB18
2N2331	+001	50	NPN T018	2N2396	+01	40	NPN HB18
2N2332	50		PNP T018	2N2397	+10	25	NPN T051
2N2333	50		PNP T018	2N2398	10	33	PNP T012
2N2334	50		PNP T018	2N2399	10	33	PNP T012
2N2335	50		PNP T018	2N2400		60	PNP T018
2N2336	50		PNP T018	2N2401	100	90	PNP T018
2N2337	50		PNP T018	2N2402	20	170	PNP T018
2N2338	+20	15	NPN T026	2N2405	+01	60	NPN T05
2N2339	+10	20	NPN F603	2N2410	100	75	NPN T05
2N2349	1.0	120	NPN T05	2N2411	+01	35	PNP T018
2N2350	+01	100	NPN T046	2N2412	+01	55	PNP T018
2N2350A	+01	100	NPN T046	2N2413	10	75	NPN T018
2N2351	+01	40	NPN T046	2N2414			
2N2351A	+01	40	NPN T046	2N2415	5.0	65	PNP T018
2N2352	+01	20	NPN T046	2N2416	5.0	30	PNP T018
2N2352A	+01	20	NPN T046	2N2423	5.0	20	PNP T03
2N2353	+10	20	NPN T046	2N2424	+10	70	PNP T05
2N2353A	+10	20	NPN T046	2N2425	+10	25	PNP T05
2N2354	50	50	NPN T022	2N2427	+50	20	NPN T018
2N2356	100		NPN J1006	2N2427	10	120	PNP T01
2N2356A	100		NPN J1006	2N2430	10	105	NPN T01
2N2357	5.0	30	PNP T041	2N2431	10	90	PNP T01
2N2358	5.0	30	PNP T041	2N2432	10	50	NPN T018
2N2359	5.0	30	PNP T041	2N2433	1 N	90	NPN T046
2N2360	10	13	PNP T012	2N2434	1 N	185	NPN T046
2N2361	10	13	PNP T012	2N2435	1 N	65	NPN T046
2N2362	10	33	PNP T012	2N2436	1 N	185	NPN T046
2N2364	+01	40	PNP T046	2N2437	1 N	15	NPN T046
2N2364A	+01	40	PNP T046	2N2438	1 N	70	NPN T046
2N2368	+0	40	NPN T018	2N2439	1 N	140	NPN T046
2N2368/51	+40	40	NPN T051	2N2440	1 N	185	NPN T05
2N2369	+40	80	NPN T018	2N2441	+01	50	NPN T05
2N2369A	+40	40	NPN T018	2N2444	1.0	75	NPN T03
2N2369/KVT	+40	80	NPN G723	2N2445	3.0	20	NPN T041
2N2369/TNT	+40	80	NPN HB12	2N2447	10	65	PNP HB06
2N2369/TPT	+40	80	NPN G724	2N2448	10	65	PNP HB07
2N2369/46	+40	80	NPN T046	2N2449	10	125	PNP HB06
2N2369/51	+40	80	NPN T051	2N2450	10	125	PNP HB07
2N2370	50	15	PNP T05	2N2451	5.0	25	PNP T024
2N2371	50	20	PNP T05	2N2453			
2N2372	50	15	PNP T018	2N2453A			
2N2373	50	20	PNP T018	2N2455	100	50	PNP T05
2N2374	100	140	PNP T05	2N2456	100	50	PNP T018
2N2375	100	75	PNP T05	2N2457	2 N	40	NPN T046
2N2376	100	75	PNP T05	2N2460	2 N	70	NPN T046
2N2377	1.0	15	PNP T018	2N2461	2 N	120	NPN T046
2N2378	+10	25	PNP T018	2N2464	2 N	170	NPN T046
USA 2N2378	+10	15	PNP T018	2N2463		40	NPN T018
2N2380	100	20	NPN T05	2N2464		75	NPN T018
2N2381	7.0	40	PNP T05	2N2465		120	NPN T018
2N2382	7.0	40	PNP T05	2N2466		170	NPN T018
2N2383	1.0	20	PNP C303	2N2467	+10	70	PNP HB14

TYPE NO.	I _{CBO} (μ A)	h _{fe}	PNP- DWG. NPN NO.	TYPE NO.	I _{CBO} (μ A)	h _{fe}	PNP - DWG. NPN NO.
2N2468	.10	30	PNP B234	JAN 2N2553	.07	20	PNP F623
2N2469	.15	30	PNP B234	2N2554	.125	20	PNP F623
2N2474			T05	2N2555	.125	20	PNP F623
2N2475	10	50	NPN B244	JAN 2N2555	.07	20	PNP F623
2N2475/46	10	50	NPN T046	2N2556	.125	20	PNP F624
2N2475/51	10	50	NPN T051	2N2557	.125	20	PNP F624
2N2476	10	20	NPN T05	JAN 2N2557	.07	20	PNP F624
2N2477	10	40	NPN T05	2N2558	.125	20	PNP F624
2N2478	2.0	30	NPN T05	2N2559	.125	20	PNP F624
2N2479	4.0	30	NPN T05	JAN 2N2559	.07	20	PNP F624
2N2481		40	NPN T018	2N2560	.125	20	PNP F623
USN 2N2481	.05	40	NPN T018	2N2561	.125	20	PNP F623
2N2482	100	25	NPN T018	2N2562	.125	20	PNP F623
2N2483	.01	40	NPN T018	2N2563	.125	20	PNP F623
2N2484	.01	100	NPN T018	2N2564	125	20	PNP B243
2N2485	1.0	10	NPN T05	2N2564/5	.65	20	PNP T05
2N2486	1.0	10	NPN T05	2N2565	125	20	PNP B243
2N2487	3.0	20	PNP T018	2N2565/5	.65	20	PNP T05
2N2488	3.0	20	PNP T018	2N2566	125	20	PNP B243
2N2489	2.5	20	PNP T018	2N2566/5	.65	20	PNP T05
2N2490	3.0	20	PNP T036	2N2567	125	20	PNP B243
2N2491	3.0	35	PNP T036	2N2567/5	.65	20	PNP T05
2N2492	2.0	25	PNP T036	2N2569	100	100	NPN
2N2493	3.0	25	PNP T036	2N2570	100	100	NPN
2N2494	50	70	PNP T07	2N2580		10	NPN T036
2N2495	50	70	PNP T012	2N2581		25	NPN T036
2N2496	50	70	PNP T012	2N2582		10	NPN T036
2N2501		150	NPN T018	2N2583		25	NPN T036
2N2509	10	40	NPN T018	2N2586	.002	80	NPN T018
2N2510	10	150	NPN T018	2N2590	25.N	40	PNP T046
2N2511	10	240	NPN T018	2N2591	25.N	70	PNP T046
2N2512	5.0	200	PNP T037	2N2592	25.N	115	PNP T046
2N2515	5 μ N	40	NPN T046	2N2593	25.N	160	PNP T046
2N2516	5.N	80	NPN T046	2N2594	.10	50	NPN T05
2N2518	5.N	40	NPN T046	2N2594/TNT	.40	80	NPN H812
2N2519	5.N	80	NPN T046	2N2594/TPT	.40	80	NPN G724
2N2520	5.N	18	NPN T046	2N2595	25.N	20	PNP T046
2N2521	5.N	36	NPN T046	2N2596	25.N	40	PNP T046
2N2522	5.N	76	NPN T046	2N2597	25.N	80	PNP T046
2N2523	2.N	60	NPN T046	2N2598	25.N	20	PNP T046
2N2524	2.N	150	NPN T046	2N2599	25.N	40	PNP T046
2N2525		10	NPN F635	2N2599A	.025	75	PNP T046
2N2526	3.0	20	PNP T03	2N2600	25.N	80	PNP T046
2N2527	3.0	20	PNP T03	2N2600A	.025	150	PNP T046
2N2528	3.0	20	PNP T03	2N2601	25.N	18	PNP T046
2N2529	.05	18	NPN T018	2N2602	25.N	36	PNP T046
2N2530	.05	30	NPN T018	2N2603	25.N	76	PNP T046
2N2531	.05	60	NPN T018	2N2604	10.N	60	PNP T046
2N2532	.05	150	NPN T018	2N2605	10.N	150	PNP T046
2N2533	.05	35	NPN T018	2N2610	2.0	9.	NPN A107
2N2534	.05	100	NPN T018	2N2611	.05	12	NPN E909
2N2535	.25	40	PNP F639	2N2613	5.0	120	PNP T01
2N2536	.25	40	PNP F639	2N2614	5.0	100	PNP T01
2N2537	.25	150	NPN T05	2N2615	.001	20	NPN T018
2N2538	.25	300	NPN T05	2N2616	.01	50	NPN T018
2N2539	.25	150	NPN T018	2N2617	.10	25	PNP B205
2N2540	.25	300	NPN T018	2N2618	.25	30	NPN T05
2N2551	.10	15	NPN T05	2N2618/46	.25	30	NPN T046
2N2552	.125	20	PNP F623	2N2630	5.0	25	PNP T018
2N2553	.125	20	PNP F623	2N2631	.01	7.5	NPN T08

TYPE NO.	I _{CBO} (μ A)	h _{fe}	PNP- DWG. NPN NO	TYPE NO.	I _{CBO} (μ A)	h _{fe}	PNP- DWG. NPN NO.
USN 2N2631	.10U	30	NPN T05	2N2720			
2N2632	.1U	40	NPN F620	2N2721			
2N2633	.1U	40	NPN F620	2N2722			
2N2634	.1U	40	NPN F620	2N2723			
2N2635		45	PNP T018	2N2724			
2N2636	10	35	PNP T041	2N2725			
2N2637	10	35	PNP T041	2N2726	1.0	60	NPN T05
2N2638	10	35	PNP T041	2N2727	1.0	110	NPN T05
2N2639				2N2728	20	40	PNP T036
2N2640				2N2729	.01	50	NPN T046
2N2641				2N2730	5.0	15	PNP T036
2N2642				2N2731	5.0	15	PNP T036
2N2643				2N2732	5.0	15	PNP T036
2N2644				2N2733	3.0	15	PNP F619
2N2645	.01	100	NPN T018	2N2734	5.0	15	PNP F619
2N2648	100	200	PNP T05	2N2735	5.0	15	PNP F619
2N2649	1.0	10	NPN T05	2N2736	5.0	15	PNP F618
2N2650	1.0	10	NPN T05	2N2737	5.0	15	PNP F618
2N2651	10	25	NPN T018	2N2738	5.0	15	PNP F618
2N2652				2N2739		10	NPN F601
2N2652a				2N2740		10	NPN F601
2N2654	8.0	50	PNP T012	2N2741		10	NPN F601
2N2656	.50	40	NPN T018	2N2742		10	NPN F601
2N2657	.1U	40	NPN T05	2N2743		10	NPN F601
2N2658	.1U	40	NPN T05	2N2746		10	NPN F601
2N2659	.125	30	PNP B243	2N2747		10	NPN F601
2N2660	.125	30	PNP B243	2N2748		10	NPN F601
2N2661	.125	30	PNP B243	2N2751		10	NPN F601
2N2662	.125	30	PNP B243	2N2752		10	NPN F601
2N2663	.125	30	PNP B243	2N2753		10	NPN F601
2N2664	.125	30	PNP B243	2N2754		10	NPN F601
2N2665	.125	50	PNP B243	2N2757		10	NPN F629
2N2666	.125	50	PNP B243	2N2758		10	NPN F629
2N2667	.125	50	PNP B243	2N2759		10	NPN F629
2N2668	.125	50	PNP B243	2N2760		10	NPN F629
2N2669	.125	50	PNP B243	2N2761		10	NPN F629
2N2670	.125	50	PNP B243	2N2763		10	NPN F629
2N2671	8.0	150	PNP T012	2N2764		10	NPN F629
2N2672	8.0	150	PNP T039	2N2765		10	NPN F629
2N2672a	8.0	40	PNP T039	2N2766		10	NPN F629
2N2692	.01	90	NPN T018	2N2769		10	NPN F629
2N2693	.01	80	NPN T018	2N2770		10	NPN F629
2N2694	.01	40	NPN T018	2N2771		10	NPN F629
2N2695	.025	30	NPN T018	2N2772		10	NPN F629
2N2696	.025	30	NPN T018	2N2781	.50	7.5	NPN T08
2N2697	.1U	40	NPN F606	2N2782	.50	7.5	NPN T08
2N2698	.1U	40	NPN F606	2N2783	.50	7.5	NPN T08
2N2706	10	115	PNP T01	2N2784	5 N	120	NPN T018
2N2707				2N2784/KVT	5 N	120	NPN G723
2N2708	.01	200	NPN B225	2N2784/TNT	5 N	120	NPN H812
2N2710	.03	40	NPN T018	2N2784/TP1	5 N	120	NPN G724
2N2711	.50	30	NPN B246	2N2784/46	.005	120	NPN T046
2N2712	.50	75	NPN B246	2N2784/51	5 N	120	NPN T051
2N2713	.50	30	NPN B246	2N2785			
2N2714	.50	75	NPN B246	2N2786	10	33	PNP T039
2N2715	.50	30	NPN J246	2N2786a	10	33	PNP T039
2N2716	.50	75	NPN B246	2N2787	.01	40	NPN T05
2N2717	1.4	50	PNP T018	2N2788	.01	80	NPN T05
2N2718	7.0	25	PNP T05	2N2789	.01	200	NPN T05
2N2719		30	NPN T018	2N2790	.01	40	NPN T018

TYPE NO.	I _{CBO} (μ A)	h _{fe}	PNP- DWG. NPN NO	TYPE NO.	I _{CBO} (μ A)	h _{fe}	PNP- DWG. NPN NO.
2N2791	+01	80	NPN T018	2N2850-2		40	NPN F622
2N2792	+01	200	NPN T018	2N2850-3		40	NPN F628
2N2793		50	PNP T036	2N2851		40	NPN B242
2N2795		100	PNP T018	2N2851-1		40	NPN T05
2N2796		60	PNP T018	2N2851-2		40	NPN F622
2N2797		80	PNP T09	2N2851-3		40	NPN F628
2N2798		50	PNP T09	2N2852		20	NPN B242
2N2799		50	PNP T09	2N2852-1		20	NPN T05
2N2800	+10	30	PNP T05	2N2852-2		20	NPN F628
2N2800/46	+10	30	PNP T046	2N2852-3		20	NPN F628
2N2800/51	+10	30	PNP T051	2N2853		40	NPN B242
	+10	75	PNP T05	2N2853-1		40	NPN T05
2N2801/46	+10	75	PNP T046	2N2853-2		40	NPN F622
2N2801/51	+10	75	PNP T051	2N2853-3		40	NPN F628
2N2802				2N2854		100	NPN B242
2N2803				2N2854-1		100	NPN T05
2N2804				2N2854-2		100	NPN F622
2N2805				2N2854-3		100	NPN F628
2N2806				2N2855		40	NPN B242
2N2807				2N2855-1		40	NPN T05
2N2808A	+01	20	NPN B225	2N2855-2		40	NPN F622
2N2809	+01	20	NPN B225	2N2855-3		40	NPN F628
2N2809A	+01	20	NPN B225	2N2856		20	NPN B242
2N2810	+01	20	NPN B225	2N2856-1		20	NPN T05
2N2810A	+01	20	NPN B225	2N2856-2		20	NPN F622
2N2811	+10	20	NPN F625	2N2856-3		20	NPN F628
2N2812	+10	40	NPN F625	2N2857	+01	50	NPN T018
2N2813	+10U	20	NPN F625	2N2858		20	NPN T05
2N2814	+10U	40	NPN F625	2N2859		20	NPN T05
		10	NPN F614	2N2860		40	PNP T018
2N2816		10	NPN F614	2N2861	+01	50	PNP T018
2N2817		10	NPN F614	2N2862	+01	25	PNP T018
2N2818		10	NPN F614	2N2863	+50	30	NPN T05
2N2819		10	NPN F614	2N2864	+50	20	NPN T05
2N2820		10	NPN F614	2N2865	+01	20	NPN B225
2N2821		10	NPN F614	2N2866		20	NPN F617
2N2822		10	NPN F614	2N2867		40	NPN F617
2N2823		10	NPN F614	2N2868		30	NPN T05
2N2824		10	NPN F614	2N2869		50	PNP T03
2N2825		10	NPN F614	2N2870		50	PNP T03
2N2828	50	20	NPN F621	2N2874	+01	7.5	NPN T08
2N2829		20	NPN F621	2N2875	+001	15	PNP F617
2N2831	+03	40	NPN T018	2N2876	+10U		NPN T060
2N2832	10	25	PNP T03	5N 2N2876	+10U	30	NPN F627
2N2833	10	25	PNP T03	2N2877	+10U	20	NPN F621
2N2834	10	25	PNP T03	2N2878	+10U	40	NPN F621
2N2835		30	PNP E512	2N2879	+10U	20	NPN F621
2N2836	+05	30	PNP T03	2N2880	+10U	40	NPN F621
2N2837	+10	30	PNP T018	2N2881		20	PNP T05
2N2838	+10	75	PNP T018	2N2882		20	PNP T05
2N2845	+20	30	NPN T018	2N2883	+50	20	NPN T05
2N2846	+20	30	NPN T05		+50	20	NPN T05
2N2847	+20	40	NPN T018	2N2885	+025	30	NPN T051
2N2848	+20	40	NPN T05	2N2886	+10	22	NPN T05
2N2849		100	NPN B242	2N2887		15	NPN HT39
2N2849-1		100	NPN T05	2N2890	100	30	NPN T05
2N2849-2		100	NPN T026	2N2891	100	50	NPN T05
2N2849-3		100	NPN F628	2N2892	+1U	30	NPN F621
2N2850		40	NPN B242	2N2893	+1U	50	NPN F621
2N2850-1		40	NPN F622	2N2894	+08	40	PNP T018

TYPE NO.	I _{CBO} (μ A)	h _{fe}	PNP- DWG. NPN NO.	TYPE NO.	I _{CBO} (μ A)	h _{fe}	PNP- DWG. NPN NO.
2N2895	2 N	50	NPN T018	2N2947	+100	50	NPN H249
2N2896	+01	50	NPN T018	2N2950	+100	50	NPN F676
2N2897	+05	50	NPN T018	2N2951	+10	20	NPN T05
2N2898	2 N	50	NPN T046	2N2952	+50	20	NPN T05
2N2899	+01	50	NPN T046	2N2953	500	200	PNP T01
2N2900	+05	50	NPN T046	2N2955		40	PNP T018
2N2903				2N2956		76	PNP T018
2N2903A				2N2957		170	PNP T018
2N2904	+02	40	PNP T05	2N2958	+125	40	NPN T05
USA 2N2904	+02	40	PNP T05	2N2959	+075	100	NPN T05
2N2904A	+01	40	PNP T05	2N2962	500	50	PNP F633
2N2904/TNT	100	75	PNP H812	2N2963	500	50	PNP F633
2N2904/TBT	10	40	PNP G724	2N2964	500	60	PNP F633
2N2905	+02	100	PNP T05	2N2965	500	60	PNP F633
USA 2N2905	+02	100	PNP T05	2N2968			
2N2905	+01	100	PNP T05	2N2969			
2N2906	+02	40	PNP T018	2N2970			
USA 2N2906	+02	40	PNP T018	2N2971			
2N2906A	+01	40	PNP T018	2N2972			
2N2907	+02	100	PNP T018	2N2973			
USA 2N2907	+02	100	PNP T018	2N2974			
2N2907A	+01	100	PNP T018	2N2975			
2N2908		12	NPN T053	2N2976			
2N2909	+01	85	NPN T046	2N2977			
2N2910				2N2978			
2N2911		20	NPN T05	2N2979			
2N2912	+20	75	PNP B253	2N2980			
2N2913				2N2981			
2N2914				2N2982			
2N2915				2N2983	10 N	20	NPN T05
2N2916				2N2984	10 N	20	NPN T05
2N2917				2N2985	10 N	40	NPN T05
2N2918				2N2986	10 N	40	NPN T05
2N2919				2N2987	+10	20	NPN T05
2N2920				2N2988	25 N	25	NPN T05
2N2923	+50	90	NPN B246	2N2989	25 N	60	NPN T05
2N2924	+50		NPN B246	2990	25 N	60	NPN T05
2N2925	+50	215	NPN B246	2N2991	25 N	25	NPN F609
2N2926	+50	35	NPN B246	2N2992	25 N	25	NPN F609
2N2927	+025	30	PNP T05	2N2993	25 N	60	NPN F609
2N2927/46	+025	30	PNP T046	2N2994	25 N	60	NPN F609
2N2927/51		30	PNP T051	2N2995	50	25	NPN F616
2N2928	500	60	PNP B225	2N2996	100	200	PNP B225
2N2929	+005	10	PNP T05	2N2999	100	200	PNP B225
2N2931	+015	30	NPN H814	2N2998	100	200	PNP B225
2N2932	+015	70	NPN H814	2999	100	100	PNP H225
2N2933	+015	45	NPN H814	2N3009		30	NPN T052
2N2934	+015	30	NPN H814	2N3010		25	NPN T018
2N2935	+015	70	NPN H814	2N3011		30	NPN T018
2N2936		125	NPN T052	2N3012		30	PNP T018
2N2939		60	NPN T05	2N3013	+30	30	NPN T052
2N2940	+025	60	NPN T05	ISN 2N3013	+30	35	NPN T052
2N2941		60	NPN T05	2N3014	+30	30	NPN T052
2N2942	25	65	PNP T09	2N3015		30	NPN T05
2N2943	25	45	PNP T09	2N3016	+10	60	NPN T05
2N2944	+10N		PNP T046	2N3017	+10	30	NPN F623
2N2945	+20N	100	PNP T046		+10	40	NPN F607A
2N2946	+50N	70	PNP T046	2N3019	+01	80	NPN T05
2N2947	100U	2.5	NPN T03	2N3020	+01	10	NPN T05
2N2948	100U	2.5	NPN T03	2N3021	+20	20	PNP T03

TYPE NO.	I_{CBO} (μA)	h_{fe}	PNP - DWG NPN NO	TYPE NO.	I_{CBO} (μA)	h_{fe}	PNP - DWG. NPN NO.
2N3022	.20	20	PNP T03	2N3089			
2N3023	.20	20	PNP T03	2N3107	.01	60	NPN T05
2N3024	.20	50	PNP T03	2N3108	.01	40	NPN T05
2N3025	.20	50	PNP T03	2N3109	.01	60	NPN T05
2N3026	.20	50	PNP T03	2N3110	.01	40	NPN T05
2N3036	.01	40	NPN T05	2N3112			
2N3037	.01	30	NPN T050	2N3113			
2N3038	.01	60	NPN T050	2N3114	.01	30	NPN T05
2N3039	.025	20	NPN T050	2N3115	25 N	25	NPN T046
2N3040	.025	40	NPN T050	2N3116	.025	100	NPN T018
2N3043				2N3117	.01	250	NPN T018
2N3044				2N3118	.10U	50	NPN T05
2N3045				2N3119	.05U	50	NPN T05
2N3046				2N3120	.01	30	NPN T05
2N3047				2N3121	.01	30	PNP T018
2N3048				2N3123	.01	100	NPN T05
2N3049				2N3124	20	50	PNP T041
2N3050				2N3125	15	30	PNP T041
2N3051				2N3126	3.0	10	PNP T041
2N3052				2N3127	10	26	PNP B226
2N3053		50	NPN T05	2N3128	.01	25	NPN G710
2N3054	1.0	25	NPNT066	2N3129	.01	100	NPN G710
2N3055	5.0	20	NPN T03	2N3130	.01	60	NPN G710
2N3056	.01	40	NPN T046	2N3131	25 N	30	NPN G710
2N3057	.01	100	NPN T046	2N3132	5.0	40	PNP T03
2N3058	.10M	40	PNP T046	2N3133	.05	40	PNP T05
2N3059	.10M	100	PNP T046	2N3134	.05	100	PNP T05
2N3060	.005	30	PNP T046	2N3135	.05	40	PNP T018
2N3061	.005	60	PNP T046	2N3136	.05	100	PNP T018
2N3062	.01	20	PNP T046	2N3137	.05	70	NPN T05
2N3063	.01	50	PNP T046	2N3138	.10	10	NPN F620
2N3064	.01	15	PNP T046	2N3139	.10	10	NPN F620
2N3065	.01		PNP T046	2N3140	.10	10	NPN F620
2N3066				2N3141	.10	10	NPN F620
2N3067				2N3142	.10	10	NPN F641
2N3068				2N3143	.10	10	NPN F641
2N3069				2N3144	.10	10	NPN F641
2N3070				2N3145	.10	10	NPN F641
2N3071				2N3146	10	30	PNP T03
2N3072	.01	30	PNP T05	2N3147	10	30	PNP T03
2N3073	.01	30	PNP T018	2N3149	2.0	10	NPN F644
2N3074	10	14	PNP T012	2N3150	2.0	10	NPN F644
2N3075	10	20	PNP T012	2N3151	2.0	10	NPN F644
2N3076		30	PNP F634	2N3152	.05	40	NPN F626
2N3077	.01	80	NPN T018	2N3153	.01		NPN T018
2N3078	.01	25	NPN T018	2N3154	.10	60	PNP C307
2N3079	5.0	10	NPN T036	2N3155	.10	60	PNP C307
2N3080	5.0	10	NPN T036	2N3156	.10	60	PNP C307
2N3081	.01	30	PNP T05	2N3157	.10	60	PNP C307
2N3081/46	.10	30	PNP T046	2N3158	.10	30	PNP C307
2N3081/51	.01	30	PNP T051	2N3159	.10	30	PNP C307
2N3082	.01	100	NPN J1001	2N3160	.10	30	PNP C307
2N3083	.01		NPN J1001	2N3161	.10	30	PNP C307
2N3084				2N3163	10	12	PNP F607
2N3085				2N3164	10	12	PNP F607
2N3086				2N3165	10	12	PNP F607
2N3087				2N3166	10	12	PNP F607
2N3088				2N3167	10	12	PNP T053
2N3088A				2N3168	10	12	PNP T053
2N3089				2N3169	10	12	PNP T053

TYPE NO.	I_{CBO} (μA)	h_{fe}	PNP- DWG. NPN NO	TYPE NO.	I_{CBO} (μA)	h_{fe}	PNP- DWG. NPN NO.
2N3170	10	12	PNP T053	2N3233	1.0	18	NPN E516
2N3171	10	12	PNP T03	2N3234	1.0	18	NPN E516
2N3172	10	12	PNP T03	2N3235	5.0	20	NPN E516
2N3173	10	12	PNP T03	2N3236	2.0	17	NPN E516
2N3174	10	12	PNP T03	2N3237	2.0	12	NPN E516
2N3175	10	10	PNP F607	2N3238	5.0	8.5	NPN E516
2N3176	10	10	PNP F607	2N3239	5.0	8.5	NPN E516
2N3177	10	10	PNP F607	2N3240	5.0	8.5	NPN E516
2N3178	10	10	PNP F607	2N3241	.10	150	NPN 8269
	10	10	PNP T053	2N3242	.01	150	NPN 8269
	10	10	PNP T053	2N3244	.05	90	PNP T05
2N3181	10	10	PNP T053	2N3245	.05	30	PNP T05
2N3182	10	10	PNP T053	2N3246	.001	150	NPN T018
	10	10	PNP T03	2N3247	.001	150	NPN G710
2N3184	10	10	PNP T03	2N3248	.05	50	PNP T018
2N3185	10	10	PNP T03	2N3249	.05	100	PNP T018
	10	10	PNP T03	2N3250	.02	50	PNP T018
2N3187	10	10	PNP F607	2N3250A	.02	50	PNP T018
2N3188	10	10	PNP F607	2N3251	.02	100	PNP T018
	10	10	PNP F607	2N3251A	.02		PNP T018
2N3190	10	10	PNP F607	2N3252	.50	30	NPN T05
2N3191	10	10	PNP T053	2N3253	.50	25	NPN T05
2N3192	10	10	PNP T053	2N3260	2.0	18	NPN F645
2N3193	10	10	PNP T053	2N3262	.001	40	NPN T039
2N3194	10	10	PNP T053	2N3263	4.0	25	NPN F643
2N3195	10	10	PNP T03	2N3264	10	20	NPN F643
2N3196	10	10	PNP T03	2N3265	4.0	25	NPN G714
2N3197	10	10	PNP T03	2N3266	10	20	NPN G714
2N3198	10	10	PNP T03	2N3267	5.0	15	PNP 8225
2N3199	.075	20	PNP F621	2N3268	.50	40	NPN T05
2N3200	.075	20	PNP F621	2N3279	5.0	10	PNP 8225
2N3201	.075	20	PNP F621	2N3280	5.0	10	PNP 8225
2N3202	.075	20	PNP T05	2N3281	5.0	10	PNP 8225
2N3203	.075	20	PNP T05	2N3282	5.0	10	PNP 8225
2N3204	.075	20	PNP T05	2N3283	10	10	PNP 8225
2N3205	.075	20	PNP F621	2N3284	10	10	PNP 8225
2N3206	.075	20	PNP F621	2N3285	10	5.	PNP 8225
2N3207	.075	20	PNP F621	2N3286	10	5.	PNP T033
2N3208	.075	20	PNP T05	2N3287	.01	15	NPN 8225
2N3209	.08	75	PNP T018	2N3288	.01	15	NPN 8225
2N3210	.01	30	NPN T018	2N3289	.01	10	NPN 8225
2N3211	25.M	50	NPN T018	2N3290	.01	10	NPN 8225
2N3212	1.0	30	PNP T037	2N3291	.10	10	NPN 8225
2N3213	1.0	30	PNP T037	2N3292	.10	10	NPN 8225
2N3214	1.0	30	PNP T037	2N3293	.10	10	NPN 8225
2N3215	1.0	25	PNP T037	2N3294	.10	10	NPN 8225
2N3216	2.0	60	PNP T05	2N3295	.10	20	NPN T05
2N3217	1.0N		PNP T046	2N3296	.10	5.	NPN F626
2N3218	1.0N		PNP T046	2N3297		2.5	NPN T03
2N3219	1.0N		PNP T046	2N3298	.50	60	NPN T018
2N3220	.01	20	NPN F642	2N3299	.01	75	NPN T05
2N3221	.01	40	NPN F642	2N3300	.01	220	NPN T05
2N3222	.01	20	NPN F642	2N3301	.01	75	NPN T018
2N3223	.01	40	NPN F642	2N3302	.01	220	NPN T018
2N3224	.10	20	PNP T05	2N3303	100	60	NPN 8260A
2N3225	.10	40	PNP T05	2N3304	.01	63	PNP T018
2N3226	.20	20	NPN T03	2N3305	.05	40	PNP T05
2N3227	.40	100	NPN T018	2N3306	.05	100	PNP T05
		5.	NPN F627	2N3307	.01	20	PNP 8260
2N3232	1.0	18	NPN E516	2N3308		10	PNP 8260

TYPE NO.	I_{CBO} (μA)	h_{fe}	PNP- DWG. NPN NO.	TYPE NO.	I_{CBO} (μA)	h_{fe}	PNP- DWG. NPN NO.
2N3309	+50	5*	NPN T05	2N3410			
2N3310	+01	10	NPN B260	2N3411			
2N3314	5+0	60	PNP T036	2N3413	+10	10	PNP T05
2N3312	5+0	60	PNP T036	2N3414	+10	150	NPN B246
2N3313	5+0	60	PNP T036	2N3415	+10	300	NPN B246
2N3314	5+0	100	PNP T036	2N3416	+10	150	NPN B246
2N3315	5+0	100	PNP T036	2N3417	+10	300	NPN B246
2N3316	5+0	100	PNP T036	2N3418	+03	20	NPN T05
2N3317	1+N	1.6	PNP B275	2N3419	+03	20	NPN T05
2N3318	1-N	1.9	PNP B275	2N3420	+03	40	NPN T05
2N3319	3+0N	3*	PNP B275	2N3421	+03	40	NPN T05
2N3320	5+0	50	PNP T018	2N3423			
2N3321	5+0	100	PNP T018	2N3424			
2N3322	5+0	100	PNP T018	2N3425			
2N3323	10	30	PNP T018	2N3426	+10	30	NPN B271
2N3324	10	30	PNP T018	2N3427	50	100	PNP T05
2N3325	10	30	PNP T018	2N3428	50	150	PNP T05
2N3326	+01	40	NPN T05	2N3429	1+0	10	NPN F647
2N3327	+50	10	NPN F627	2N3430	1+0	10	NPN F647
2N3337	+025	30	NPN T038	2N3431	1+0	10	NPN F647
2N3338	+025	30	NPN B225	2N3432	1+0	10	NPN F647
2N3339	+025	30	NPN B225	2N3433	1+0	10	NPN F647
2N3340	1+N	40	NPN T046	2N3434	1+0	10	NPN F647
2N3341	+01	40	PNP T046	2N3435	+050	50	NPN T05
2N3342	+02	30	PNP T05	2N3439	+02	40	NPN T05
2N3343	+003	20	PNP T05	2N3440	+02	40	NPN T05
2N3344	+002	25	PNP T05	2N3441	5+0	20	NPN T066
2N3345	+005	15	PNP T05	2N3442	30	20	NPN T03
2N3346	+005	25	PNP T05	2N3443	5+0	20	PNP T05
2N3347				2N3444	+500	20	NPN T05
2N3348				2N3445	+10	20	NPN T03
2N3349				2N3446	+10	20	NPN T03
2N3350				2N3447	+10	40	NPN T03
2N3351				2N3448	+10	40	NPN T03
2N3352				2N3449	3+0	20	PNP T018
2N3371	7+0	25	PNP T018	2N3450	+20	40	NPN T05
2N3374	50-N	10	NPN T05	2N3461	3+0	90	PNP T05
2N3375	5+0	5*	NPN T060	2N3462	10	150	NPN T018
2N3386	2+0	1.8	NPN T05	2N3463	+002	150	NPN T018
2N3389	2+0	1.8	NPN T05	2N3467	+100	40	PNP T05
2N3390	+10	500	NPN B246	2N3468	+100	25	PNP T05
2N3391	+10	250	NPN B246	2N3469	+100	100	NPN T05
2N3391A	+10	250	NPN B246	2N3470	20	100	NPN F629
2N3392	+10	150	NPN B246	2N3471	20	100	NPN F629
2N3393	+10	90	NPN B246	2N3472	20	100	NPN F629
2N3394	+10	55	NPN B246	2N3473	20	100	NPN F629
2N3395	+10	150	NPN B246	2N3474	20	350	NPN F629
2N3396	+10	90	NPN B246	2N3475	20	350	NPN F629
2N3397	+10	55	NPN B246	2N3476	20	350	NPN F629
2N3398	+10	55	NPN B246	2N3477	20	350	NPN F629
2N3399	8+0	10	PNP B225	2N3478	+02	25	NPN B269A
2N3400	5+0	35	PNP T09	2N3485	+02	40	PNP T046
2N3401	+10	4*	PNP T05	2N3485A	+01	40	PNP T0.6
2N3402	+10	150	NPN G721	2N3486	+02	100	PNP T046
2N3403	+10	350	NPN G721	2N3486A	+01	100	PNP T046
2N3404	+10	150	NPN G721	2N3487	+10	20	NPN T061
2N3405	+10	350	NPN G721	2N3488	+10	20	NPN T061
2N3407	+20	10	NPN B225	2N3489	+10	15	NPN T061
2N3408	+400		PNP F626	2N3490	+10	40	NPN T061
2N3409				2N3491	+10	40	NPN T061

TYPE NO	I _{CBO} (μ A)	h _{fc}	PNP- DWG. NPN NO	TYPE NO.	I _{CBO} (μ A)	h _{fe}	PNP- DWG. NPN NO
2N3492	.10	30	NPN T061	2N3580	.05	150	PNP T046
2N3493	5	40	NPN B225	2N3581	.02	100	PNP T046
2N3494	.10	40	PNP T05	2N35A2	.07	200	PNP T046
2N3495	.10	40	PNP T05	2N3583	10	40	NPN T066
2N3496	.10	40	PNP T018	2N3584	1.0	8.	NPN T066
2N3497	.10	40	PNP T018	2N3585	1.0	8.	NPN T066
	.05U	40	NPN T05	2N3588	8.0	30	PNP B273
2N3499	.05U	100	NPN T05	2N3589	.001	30	NPN F610
2N3500	.05U	40	NPN T05	2N3590	.001	75	NPN F610
2N3501	.05U	100	NPN T05	2N3591	.001	30	NPN B230
2N3502	.01	100	PNP T05	2N3592	.001	75	NPN B220
2N3503	.01	100	PNP T05	2N3597	.001	30	NPN F616
2N3504	.01	100	PNP T018	2N3598	.001	75	NPN F616
	.01	100	PNP T05	2N3599	.001	30	NPN F616A
2N3506	1.0	40	NPN T05	2N3596	.001	75	NPN F616A
2N3507	1.0	30	NPN T05	2N3597	.10U	75	NPN T063
2N3508	.20	40	NPN T046	2N3598	.10U	75	NPN T063
2N3509	.20	100	NPN T046	2N3599	.10U	75	NPN T063
2N3510	25 N	25	NPN T052	2N3600	.01	20	NPN B225
2N3511	25 N	30	NPN T052	2N3601	200	60	PNP J258
2N3512	.50	10	NPN T05	2N3602	200	60	PNP B258
2N3513				2N3603	200	60	PNP J258
2N3514				2N3604	200	60	PNP F650
2N3515				2N3605	.50	30	NPN B246
2N3516				2N3606	.50	30	NPN B246
2N3517				2N3607	.50	30	NPN B246
2N3518				2N3611	5.0	35	PNP T03
2N3519				2N3612	5.0	35	PNP T03
2N3520				2N3613	5.0	60	PNP T03
2N3521				2N3614	5.0	60	PNP T03
2N3522				2N3615	5.0	30	PNP T03
2N3523				2N3616	5.0	30	PNP T03
2N3524				2N3617	5.0	45	PNP T03
2N3526	1.0	30	NPN T05	2N3618	5.0	45	PNP T03
2N3527	.1N	40	PNP T046	2N3619	.025	40	NPN T05
2N3543	.01	10	NPN T03	2N3620	.025	30	NPN B521
2N3544	.10	50	NPN T018	2N3621	.025	40	NPN T061
2N3545	.01	40	PNP T018	2N3622	.025	40	NPN T061
2N3546	.01	30	PNP T018	2N3623	.001	40	NPN T05
2N3547	.025	100	PNP T018	2N3624	.001	30	NPN B521
2N3548	.01	100	PNP T018	2N3625	.001	40	NPN T061
2N3549	.01	100	PNP T018	2N3626	.001	40	NPN T061
2N3550	.001	200	PNP T018	2N3627	.001	40	NPN T05
2N3551	10	20	NPN G709	2N3628	.001	30	NPN B521
2N3552	10	20	NPN G709	2N3629	.001	40	NPN T061
2N3553	1.0	5.	NPN T039	2N3630	.001	40	NPN T061
2N3554	.50	20	NPN T05	2N3632	5.0	10	NPN T060
2N3563	.05	20	NPN B274A	2N3633	.005	50	NPN T018
2N3564	.05	20	NPN B274A	2N3633/KVT	5 N	150	NPN G723
2N3565	.05	120	NPN B274A	2N3633/TNT	5 N	150	NPN H812
2N3566	.05	150	NPN B274	2N3633/TPT	5 N	150	NPN G724
2N3567	.05	40	NPN B274	2N3633/46	5 N	150	NPN T046
2N3568	.05	40	NPN B274	2N3633/51	5 N	150	NPN T051
2N3569	.05	100	NPN B274	2N3634	.10U	50	PNP T05
2N3570	.01	20	NPN B225	2N3635	.10U	100	PNP T05
2N3571	.01	20	NPN B225	2N3636	.10U	100	PNP T05
2N3572	.01	20	NPN B225	2N3637	.10U	100	PNP T05
2N3576	.01	40	PNP B225	2N3638	.035	30	PNP B274
2N3577	.10	12	NPN T053	2N3639	.01	30	PNP B274A
2N3579	.05	75	PNP T046	2N3640	.01	30	PNP B274A

TYPE NO.	I_{CBO} (μA)	h_{fe}	PNP- NPN	DWG. NO.
2N3641	.05	40	NPN	0274
2N3642	.05	40	NPN	0274
2N3643	.05	100	NPN	0274
2N3644	.035	100	PNP	0274
2N3645	.035	100	PNP	0274
2N3646	.50	30	NPN	0274A
2N3647	25 N	25	NPN	T046
2N3648	25 N	30	NPN	T046
2N3659	.01	20	NPN	T05
2N3660	.001	25	PNP	T05
2N3661	.001	25	PNP	T05
2N3665	.05	40	NPN	T05
2N3666	.05	100	NPN	T05
USA 2N5591	3.0	25	PNP	T028
USA 2N5592	3.0	25	PNP	T028
USA 2N5593	3.0	25	PNP	T028

OUTLINE DRAWINGS

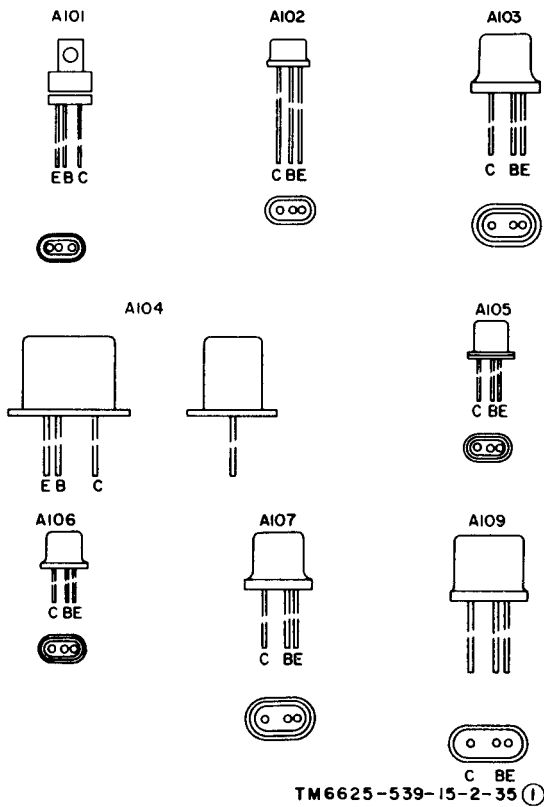

Figure E-1①. Transistor outline drawings (part 1 of 20).

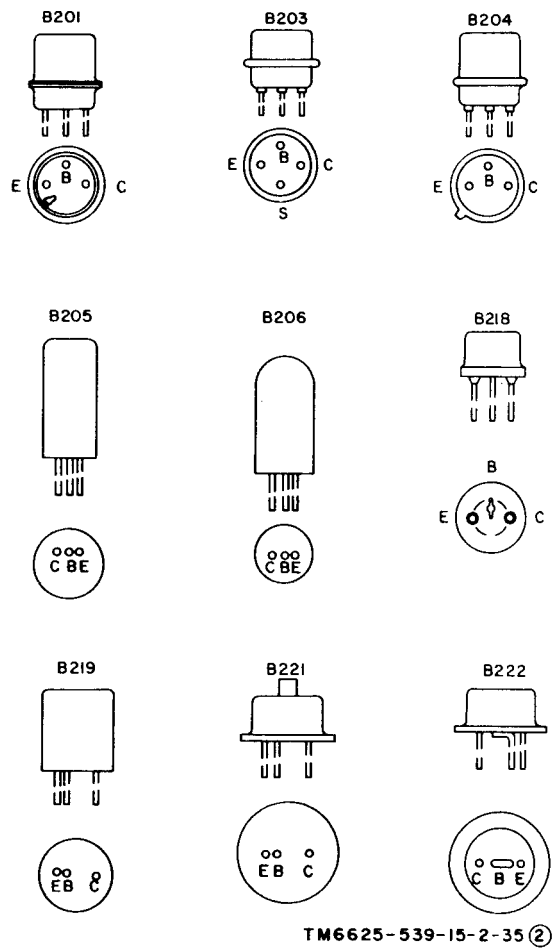

Figure E-1②. Transistor outline drawings (part 2 of 20).

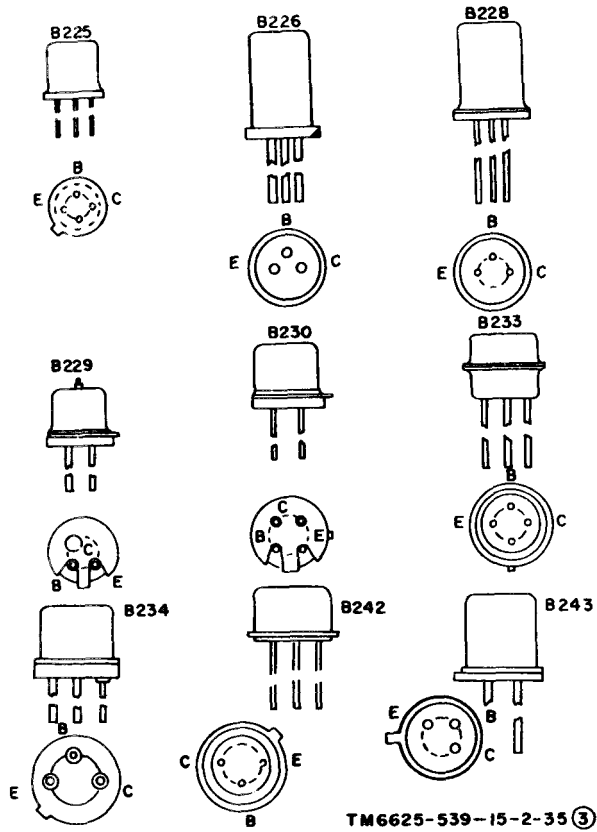

Figure E-1 ③. Transistor outline drawings (part 3 of 20).

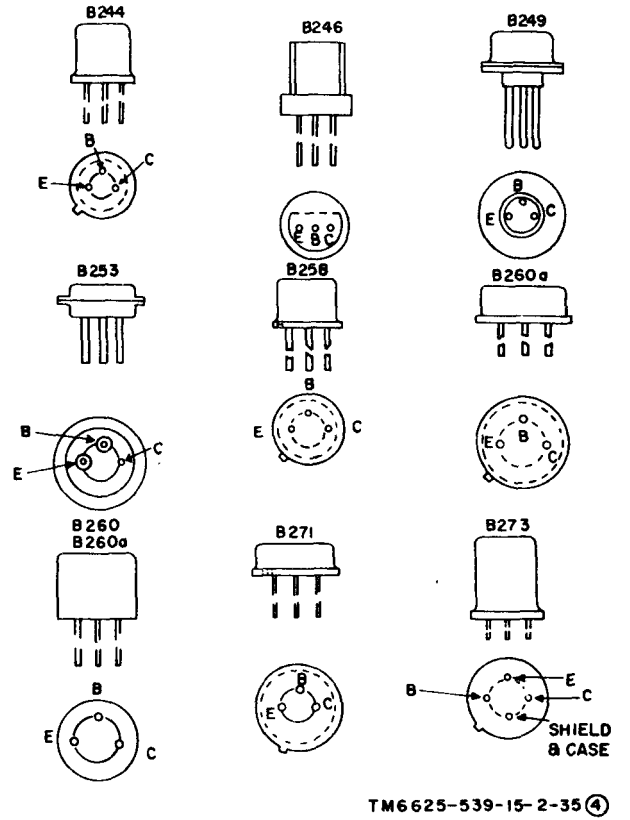

Figure E-1 ④. Transistor outline drawings (part 4 of 20).

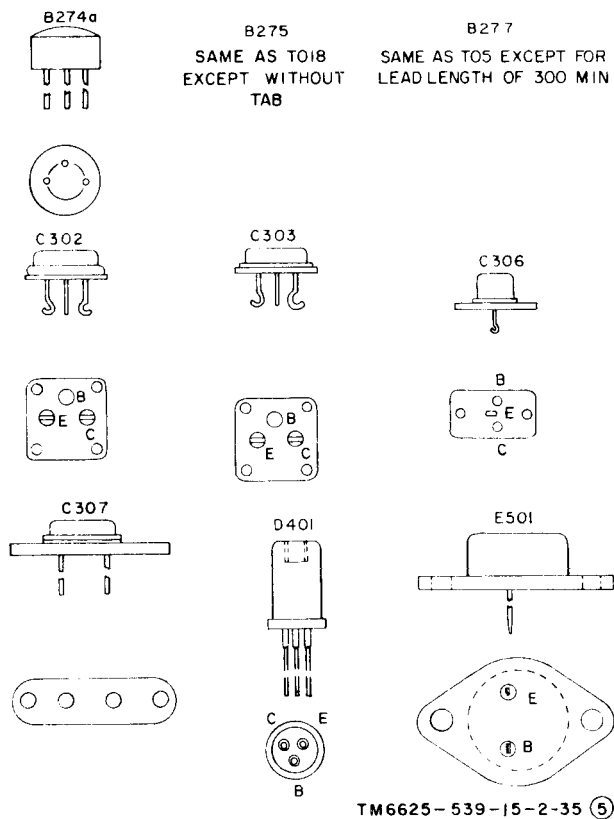

Figure E-1⑤ Transistor outline drawings (part 5 of 20).

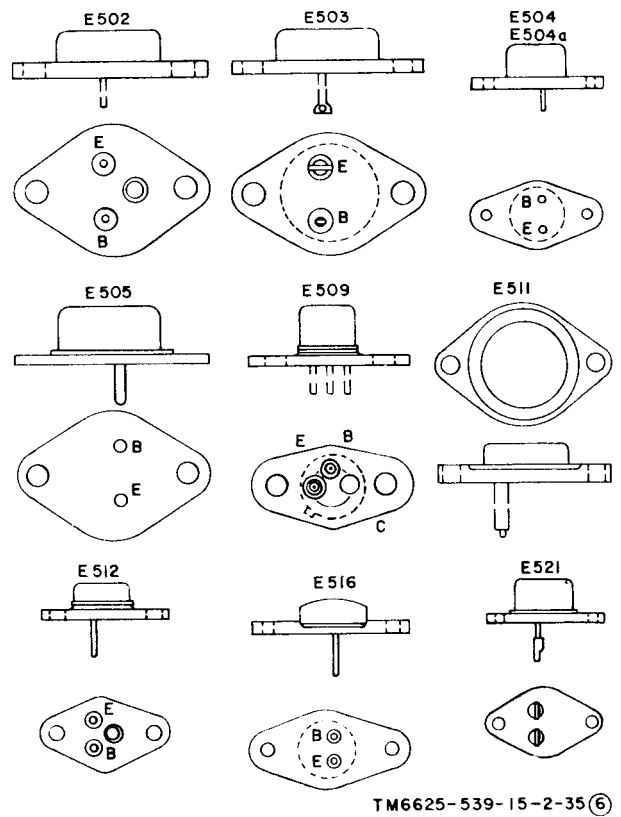

Figure E-1⑥ Transistor outline drawings (Part 6 of 20).

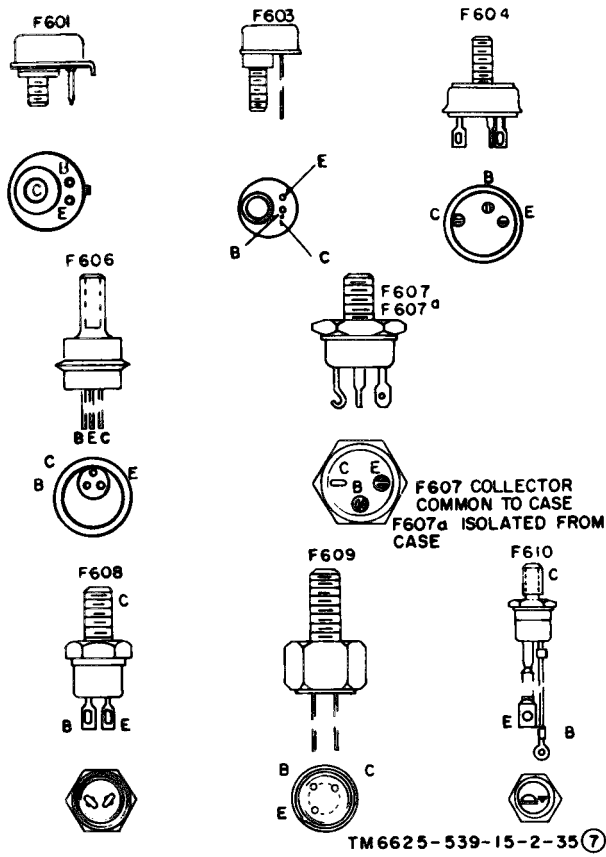

Figure E-1(7). Transistor outline drawings (part 7 of 20).

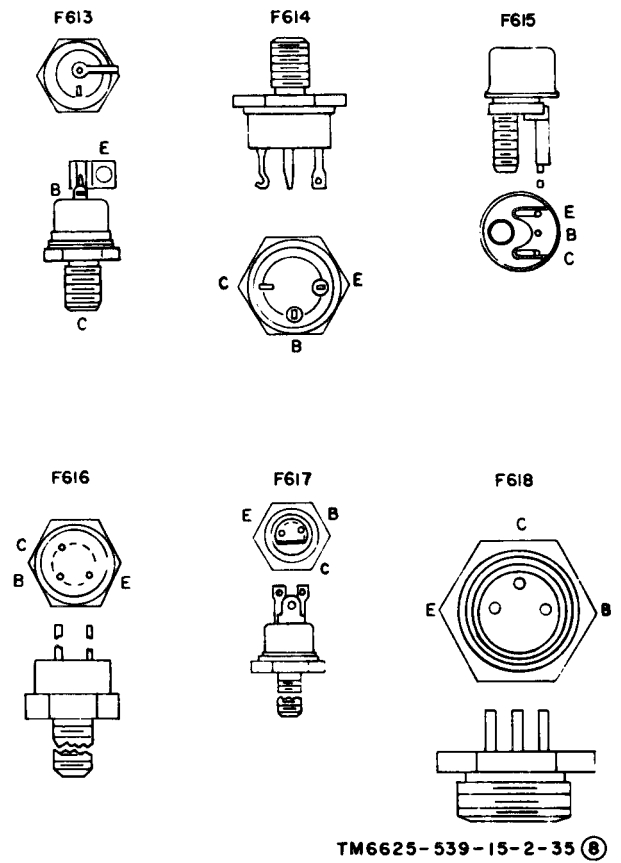

Figure E-1(8). Transistor outline drawings (part 8 of 20).

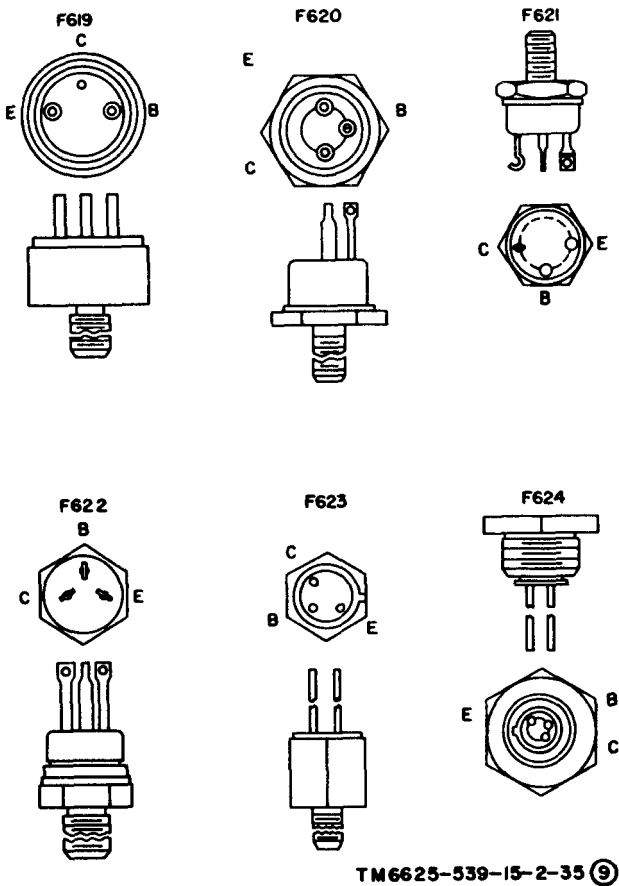

Figure E-1 ⑨. Transistor of outline diagram (part 9 of 20).

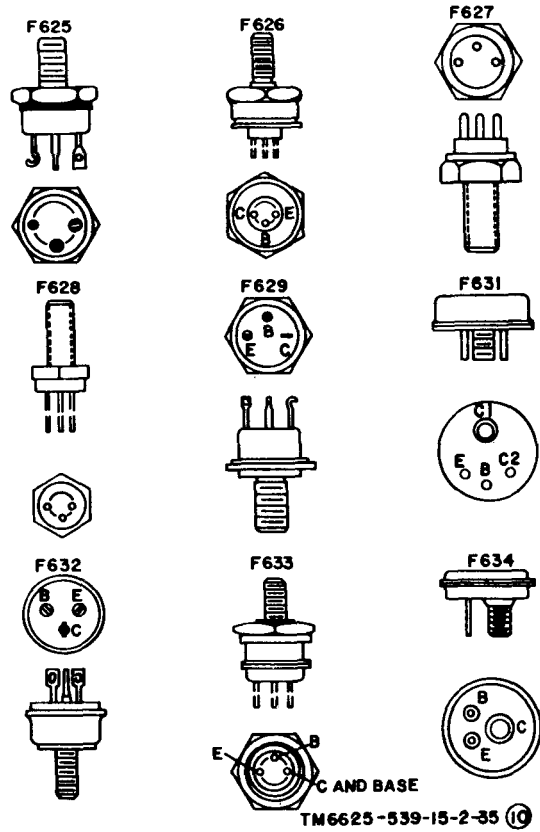
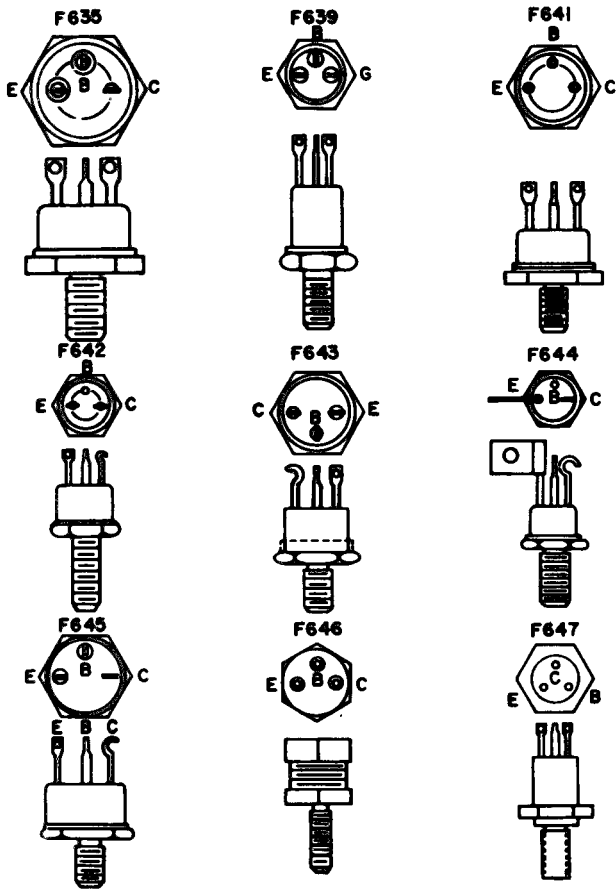
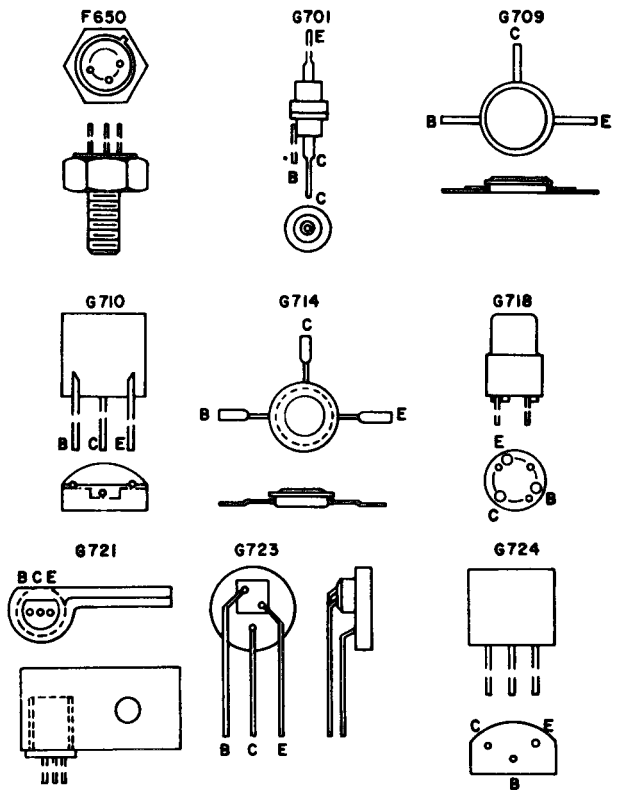

Figure E-1 ⑩. Transistor outline diagrams (part 10 of 20.)



TM6625-539-15-2-35 (11)

Figure E-1 (11). Transistor outline drawings (part 11 of 20).



TM6625-539-15-2-35 (12)

Figure E-1 (12). Transistor outline drawings (part 12 of 20).

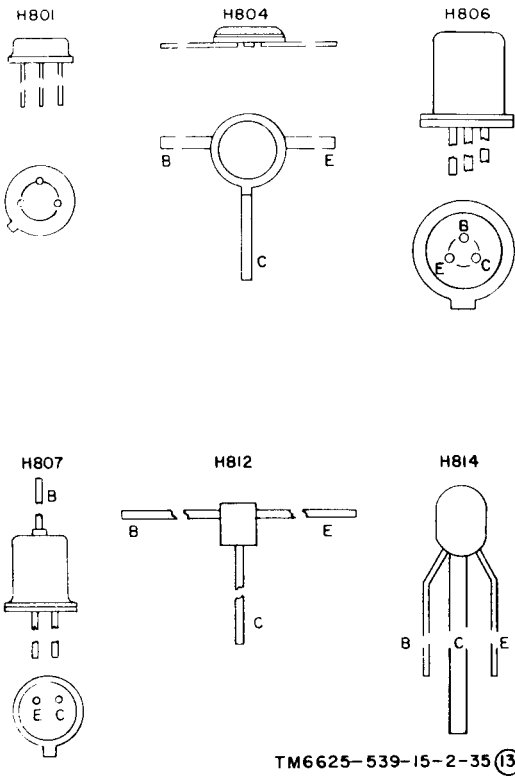

TM6625-539-15-2-35 (13)

Figure E-1(13). Transistor outline drawings (part 13 of 20).

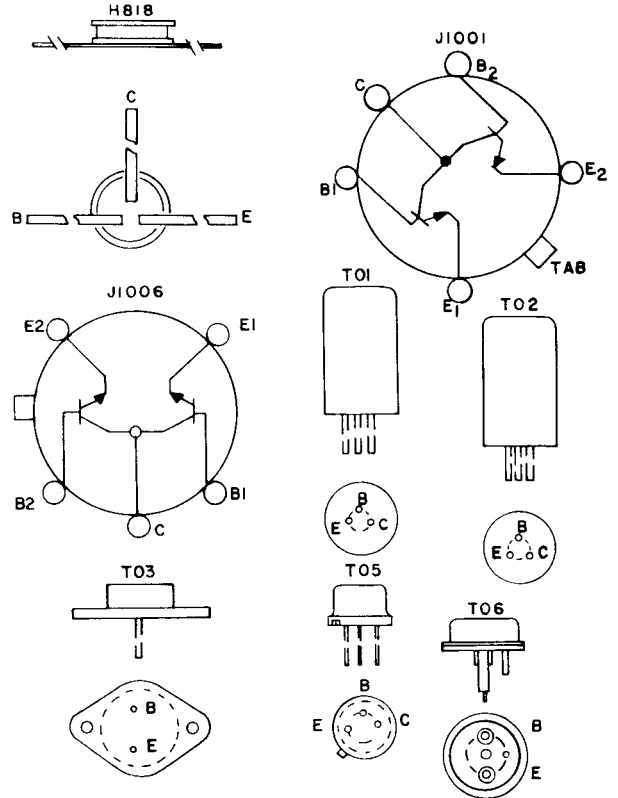

TM6625-539-15-2-35 (14)

Figure E-1(14). Transistor outline drawings (part 14 of 20).

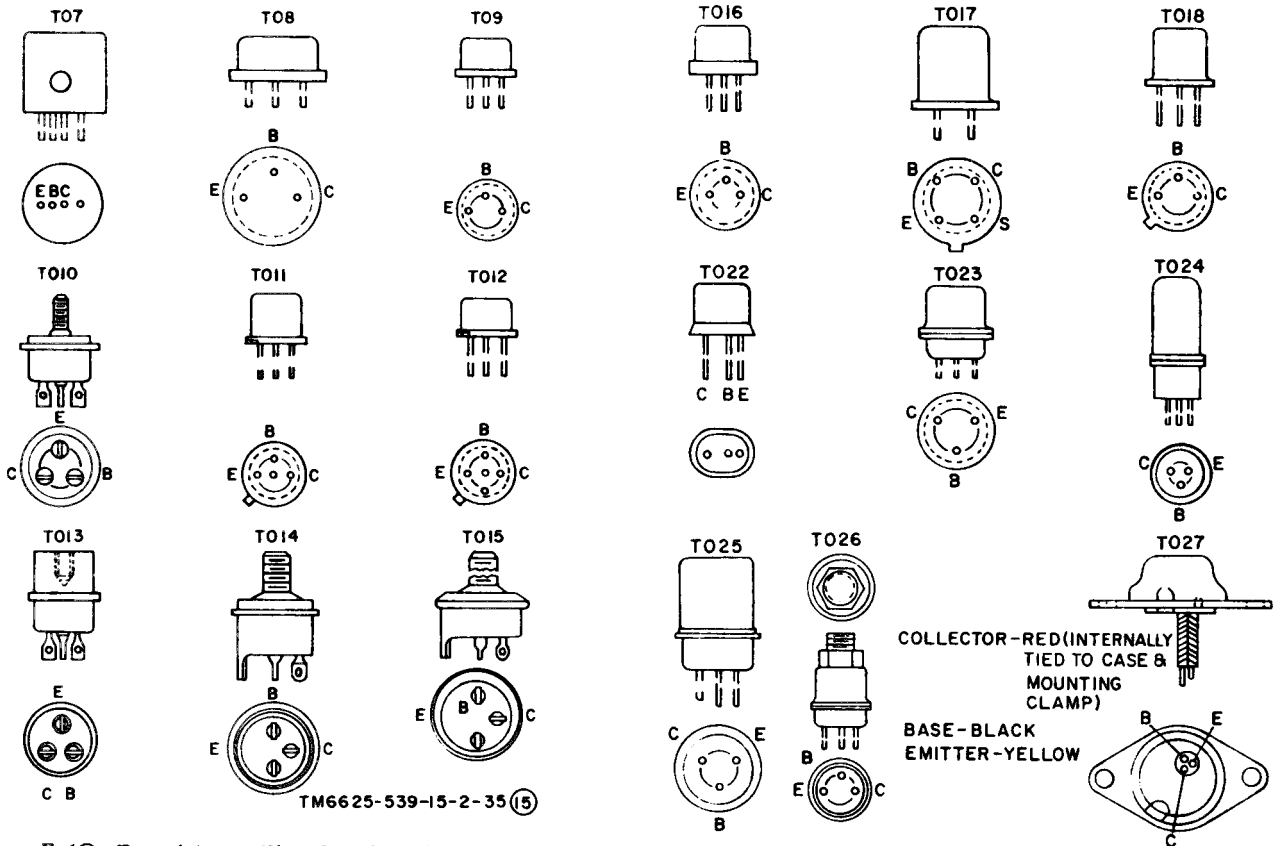
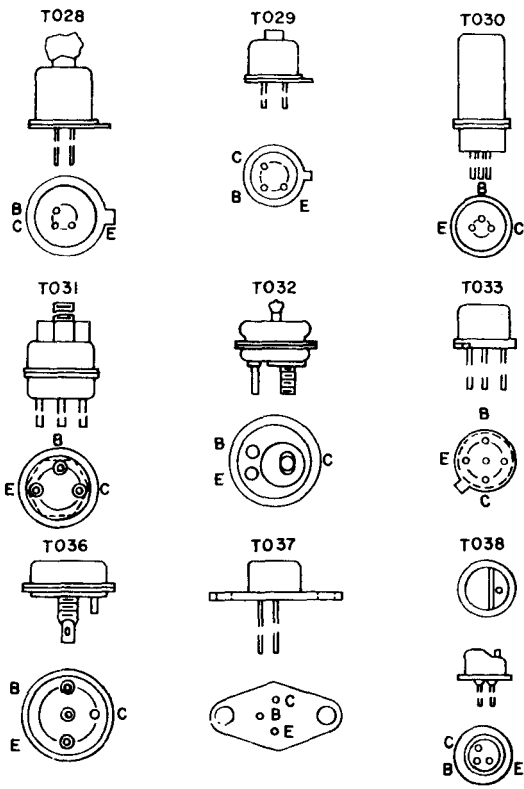
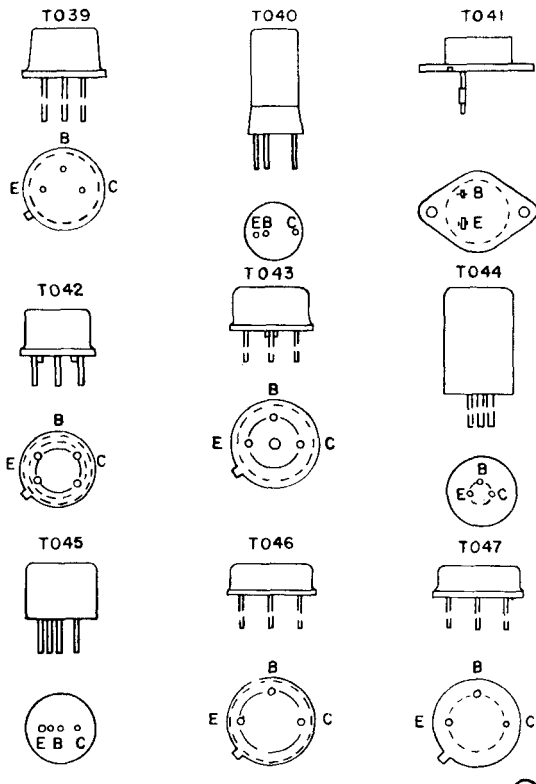

Figure E-1(15). Transistor outline drawings (part 15 of 20).

Figure E-1(16). Transistor outline drawings (part 16 of 20).



TM6625-539-15-2-35 (17)



TM6625-539-15-2-35 (18)

Figure E-1(17). Transistor outline drawings (part 17 of 20).

Figure E-1(18). Transistor outline drawings (part 18 of 20).

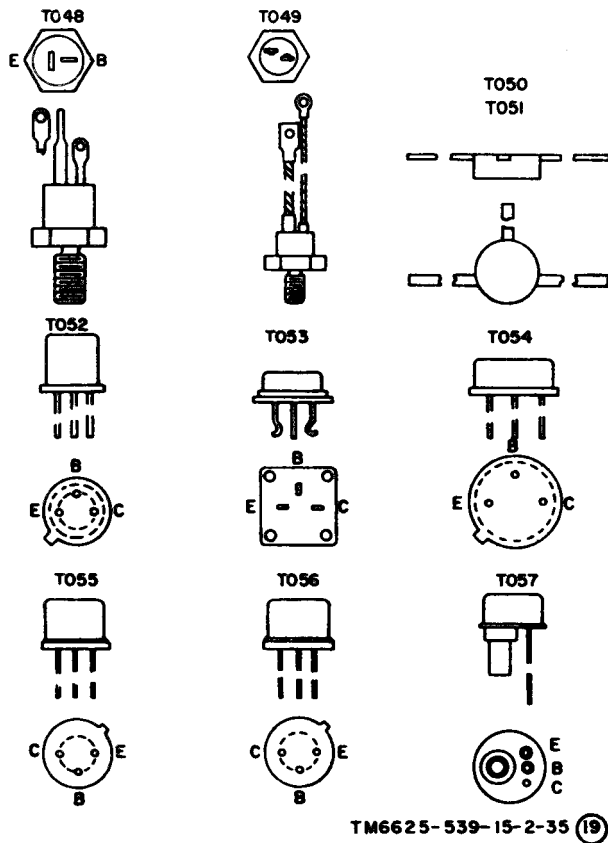

Figure E-1(19). Transistor outline drawings (part 19 of 20).

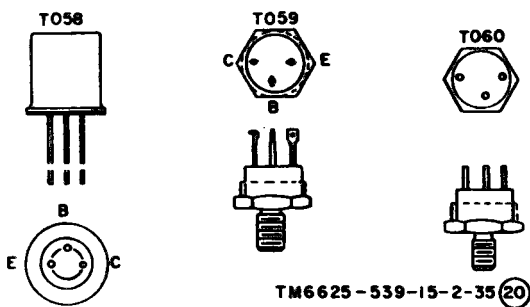

Figure E-1(20). Transistor outline drawings (part 20 of 20)

By Order of the Secretary of the Army:

Official:

KENNETH G. WICKHAM,
Major General, United States Army,
The Adjutant General.

W. C. WESTMORELAND,
General, United States Army,
Chief of Staff.

Distribution:

Active Army:

USASA (2)
 CNGB (1)
 ACSC-E (2)
 Dir of Trans (1)
 CofEngrs (1)
 TSG (1)
 CofSptS (1)
 USAARENBD (2)
 USAAVNTBD (5)
 USACDC Agcy (1)
 USAMC (5)
 USCONARC (5)
 A RADCOM (5)
 ARADCOM Rgn (2)
 OS Maj Comd (4)
 LOGCOMD (2)
 USAMICOM (4)
 USASTRATCOM (4)
 USAESC (70)
 MDW (1)
 Armies (2) except USA Panama (5)
 Corps (2)
 USAC (3)
 Svc Colleges (2)
 USASCS (5)
 USASESS (2)
 USAADS (2)
 USAAMS (2)
 USAARMS (2)
 USAIS (2)
 USAES (2)
 USASA Tng Cen & Sch (5)
 USATC Armor (2)
 USATC Inf (2)
 USASTC (2)
 WRAMC (1)
 Army Pic Cen (2)
 USACDCEC (10)
 USAATC (5)
 Engr Cen (5)
 Instl (2) except
 Fort Gordon (10)
 Fort Huachuca (10)

Fort Carson
 Fort Knox (12)
 WSMR (5)
 Army Dep (2) except
 LBAID (30)
 SAAD (42)
 TOAD (14)
 LEAD (7)
 SHAD (3)
 NAAD (5)
 SVAD (5)
 CHAD (3)
 ATAD (10)
 RRAD (10)
 GCAD (10)
 Gen Deps (2)
 Sig Sec Gen Deps (5)
 Sig Dep (12)
 Sig FLDMS (2)
 AMS (1)
 USAERDAA (2)
 USAERDAW (13)
 USACRREL (2)
 MAAG (2)
 USARMIS (2)
 Edgewood Arsenal (5)
 Redstone Arsenal (5)
 507th USASA Gp (5)
 508th USASA Gp (5)
 318th USASA Bn (5)
 319th USASA Bn (5)
 2nd USASA Fld Sta (5)
 3rd USASA Fld Sta (5)
 4th USASA Fld Sta (5)
 5th USASA Fld Sta (5)
 12th USASA Fld Sta (5)
 9th USASA Fld Sta (5)
 13th USASA Fld Sta (5)
 14th USASA Fld Sta (5)
 15th USASA Fld Sta (5)
 102nd USASA Det (5)
 75th USASA Co (5)
 600th USASA Co (5)
 177th USASA Co (5)

182nd USASA Co (5)
 183rd USASA Co (5)
 184th USASA Co (5)
 52nd USASA Sp Op Comd (5)
 Units organized under following TOE's (2 copies each):
 1-100 29-26
 1-101 29-27
 6-615 29-35
 6-616 29-36
 7 29-37
 11-38 29-500
 11-68 (FZ, KH)
 11-57 30-34
 11-85 32-52
 11-86 32-56
 11-87 32-57
 11-97 32-58
 11-98 32-77
 11-117 32-78
 11-155 37
 11-127 39-51
 11-157 44-2
 11-158 44-12
 11-237 44-236
 11-500 (AA-AC, 44-536
 KA-KD, NA- 44-568
 NC, RD, RL, 47
 RM, RO, RQ, 55-50
 RR, RS, RV, 55-89
 RX, TE, FT, 55-99
 TG) 55-405
 11-587 55-406
 11-592 55-407
 11-597 55-457
 17 55-458
 29-1 55-459
 29-11 55-479
 29-15 55-510
 29-16 57
 29-17 57-100
 29-21 67
 29-25 77-100

NG: State AG (3).

USAR: None.

For explanation of abbreviations used, see AR 320-50.

CCOLOR CODE MARKING FOR MILITARY STANDARD CAPACITORS

GROUP I Capacitors, Fixed, Various-Dielectrics, Styles CM, CN, CY, and CB

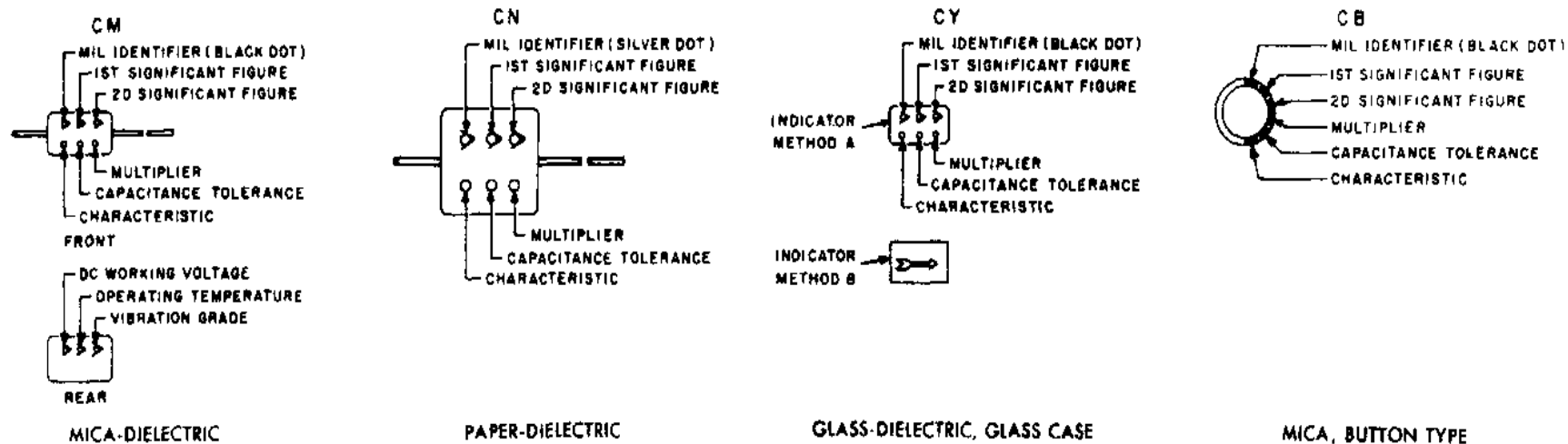

COLOR CODE TABLES

TABLE I - For use with Group I, Styles CM, CN, CY and CB

COLOR	MIL ID	1st SIG FIG	2nd SIG FIG	MULTIPLIER ¹	CAPACITANCE TOLERANCE				CHARACTERISTIC ²				DC WORKING VOLTAGE	OPERATING TEMP. RANGE	VIBRATION GRADE
					CM	CN	CY	CB	CM	CN	CY	CB			
BLACK	CM, CY, CB	0	0	1			± 20%	± 20%		A				-55° to +70°C	10-55 cps
BROWN		1	1	10						B	E		B		
RED		2	2	100	± 2%		± 2%	± 2%	C		C			-55° to +85°C	
ORANGE		3	3	1,000		± 30%			D			D	300		
YELLOW		4	4	10,000					E					-55° to +125°C	10-2,000 cps
GREEN		5	5		± 5%				F				500		
BLUE		6	6											-55° to +150°C	
PURPLE (VIOLET)		7	7												
GREY		8	8												
WHITE		9	9												
GOLD				0.1			± 5%	± 5%							
SILVER	CN				± 10%	± 10%	± 10%	± 10%							

GROUP II Capacitors, Fixed Ceramic-Dielectric (General Purpose) Style CK

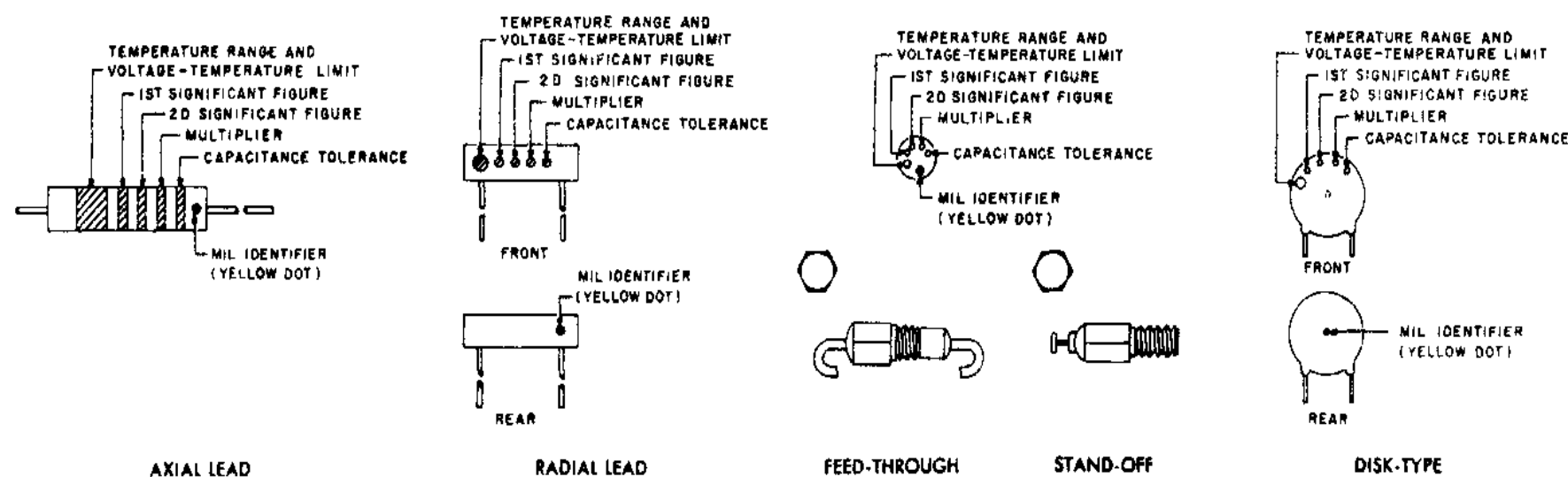

TABLE II - For use with Group II, General Purpose, Style CK

COLOR	TEMP. RANGE AND VOLTAGE-TEMP LIMITS ³	1st SIG FIG	2nd SIG FIG	MULTIPLIER ¹	CAPACITANCE TOLERANCE	MIL ID
BLACK		0	0	1	± 20%	
BROWN	AW	1	1	10	± 10%	
RED	AX	2	2	100		
ORANGE	BY	3	3	1,000		
YELLOW	AV	4	4	10,000		CK
GREEN	CZ	5	5			
BLUE	BV	6	6			
PURPLE (VIOLET)		7	7			
GREY		8	8			
WHITE		9	9			
GOLD						
SILVER						

TABLE III - For use with Group III, Temperature Compensating, Style CC

COLOR	TEMPERATURE COEFFICIENT ⁴	1st SIG FIG	2nd SIG FIG	MULTIPLIER ¹	CAPACITANCE TOLERANCE		MIL ID
					Capacitances over 10uuf	Capacitances 10uuf or less	
BLACK	0	0	0	1		± 2.0uuf	CC
BROWN	30	1	1	10	± 1%		
RED	80	2	2	100	± 2%	± 0.25uuf	
ORANGE	150	3	3	1,000			
YELLOW	± 220	4	4				
GREEN	± 330	5	5		± 5%	± 0.5uuf	
BLUE	470	6	6				
PURPLE (VIOLET)	± 750	7	7				
GREY		8	8	0.01			
WHITE		9	9	0.1	± 10%		
GOLD	± 100					± 1.0uuf	
SILVER							

GROUP III Capacitors, Fixed, Ceramic-Dielectric (Temperature Compensating) Style CC

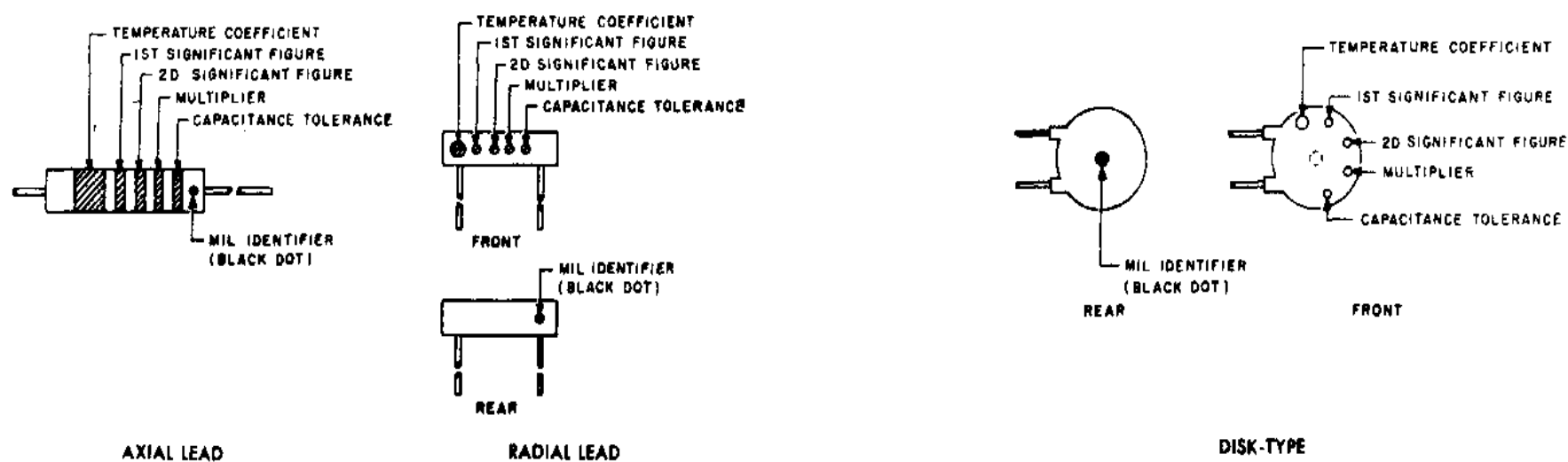

1. The multiplier is the number by which the two significant (SIG) figures are multiplied to obtain the capacitance in uuf.
2. Letters indicate the Characteristics designated in applicable specifications: MIL-C-5, MIL-C-91, MIL-C-11272, and MIL-C-10950 respectively.
3. Letters indicate the temperature range and voltage-temperature limits designated in MIL-C-11015.
4. Temperature coefficient in parts per million per degree centigrade.

Figure 10-2. Color-code marking for MIL-STD capacitors.

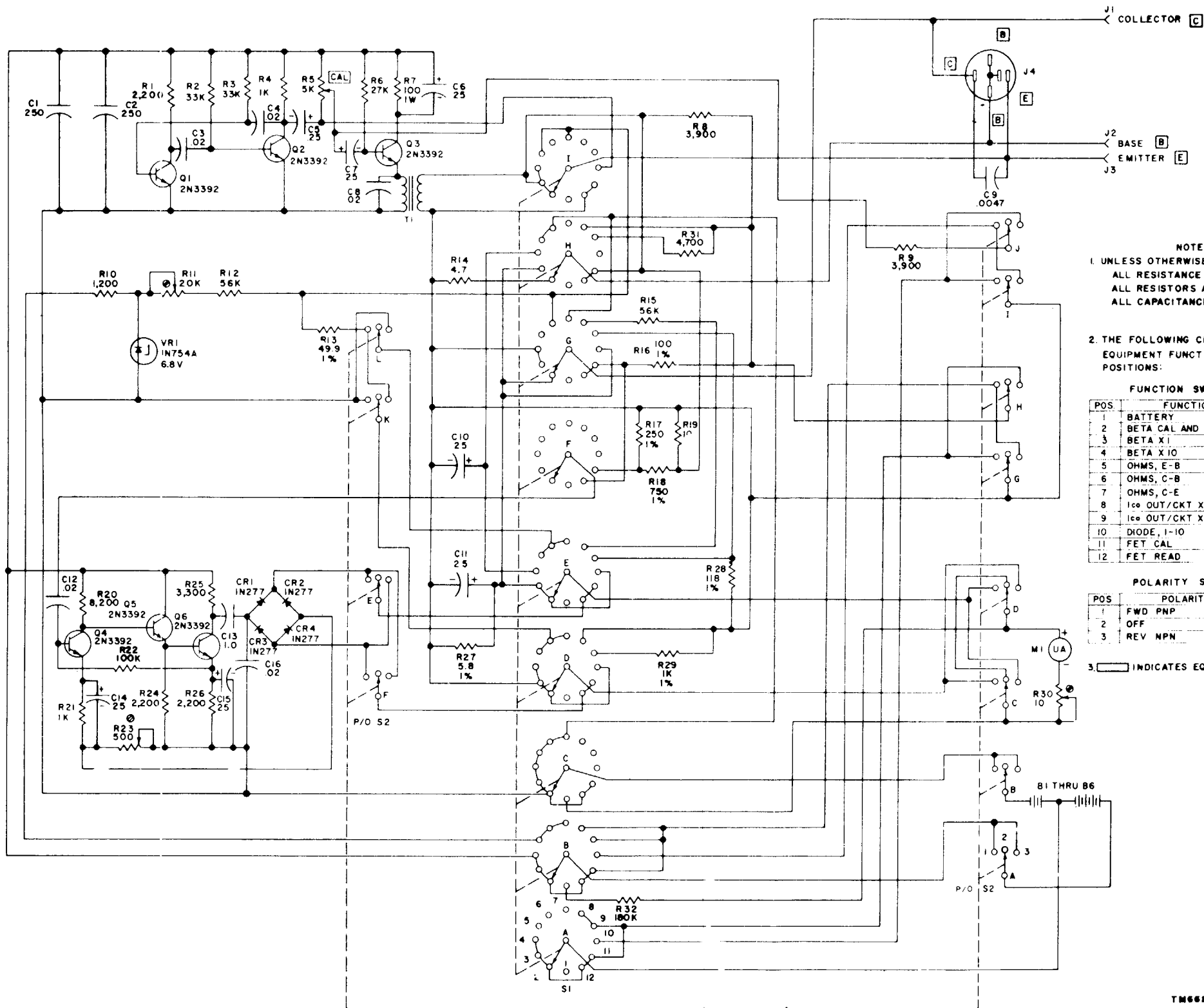

NOTES:
 1. UNLESS OTHERWISE SPECIFIED:
 ALL RESISTANCE VALUES ARE IN OHMS
 ALL RESISTORS ARE 1/2 W, $\pm 5\%$
 ALL CAPACITANCE VALUES ARE IN UF

2. THE FOLLOWING CHARTS RELATE
 EQUIPMENT FUNCTIONS TO SWITCH
 POSITIONS:

FUNCTION SWITCH S1	
POS	FUNCTION
1	BATTERY
2	BETA CAL AND DIODE IN/CKT
3	BETA X1
4	BETA X10
5	OHMS, E-B
6	OHMS, C-B
7	OHMS, C-E
8	I _{cc} OUT/CKT X1
9	I _{cc} OUT/CKT X10
10	DIODE, I-10
11	FET CAL
12	FET READ

POLARITY SWITCH S2	
POS	POLARITY
1	FWD PNP
2	OFF
3	REV NPN

3. INDICATES EQUIPMENT MARKING.

Figure 10-3. Test Set, Transistor, TS-1836B/U, schematic diagram

FIGURE 10-3.

RECOMMENDED CHANGES TO EQUIPMENT TECHNICAL PUBLICATIONS



THEN...JOT DOWN THE
DOPE ABOUT IT ON THIS FORM.
CAREFULLY TEAR IT OUT, FOLD IT
AND DROP IT IN THE MAIL.

SOMETHING WRONG WITH PUBLICATION

FROM: (PRINT YOUR UNIT'S COMPLETE ADDRESS)

DATE SENT

PUBLICATION NUMBER

PUBLICATION DATE

PUBLICATION TITLE

BE EXACT PIN-POINT WHERE IT IS

PAGE
NO.

PARA-
GRAPH

FIGURE
NO.

TABLE
NO.

IN THIS SPACE, TELL WHAT IS WRONG
AND WHAT SHOULD BE DONE ABOUT IT.

TEAR ALONG PERFORATED LINE

PRINTED NAME, GRADE OR TITLE AND TELEPHONE NUMBER

SIGN HERE

THE METRIC SYSTEM AND EQUIVALENTS

WEIGHT MEASURE

1 Centimeter = 10 Millimeters = 0.01 Meters = 0.3937 Inches
 1 Meter = 100 Centimeters = 1000 Millimeters = 39.37 Inches
 1 Kilometer = 1000 Meters = 0.621 Miles

WEIGHTS

1 Gram = 0.001 Kilograms = 1000 Milligrams = 0.035 Ounces
 1 Kilogram = 1000 Grams = 2.2 lb.
 1 Metric Ton = 1000 Kilograms = 1 Megagram = 1.1 Short Tons

LIQUID MEASURE

1 Milliliter = 0.001 Liters = 0.0338 Fluid Ounces
 1 Liter = 1000 Milliliters = 33.82 Fluid Ounces

SQUARE MEASURE

1 Sq. Centimeter = 100 Sq. Millimeters = 0.155 Sq. Inches
 1 Sq. Meter = 10,000 Sq. Centimeters = 10.76 Sq. Feet
 1 Sq. Kilometer = 1,000,000 Sq. Meters = 0.386 Sq. Miles

CUBIC MEASURE

1 Cu. Centimeter = 1000 Cu. Millimeters = 0.06 Cu. Inches
 1 Cu. Meter = 1,000,000 Cu. Centimeters = 35.31 Cu. Feet

TEMPERATURE

$5/9(^{\circ}\text{F} - 32) = ^{\circ}\text{C}$
 212° Fahrenheit is equivalent to 100° Celsius
 90° Fahrenheit is equivalent to 32.2° Celsius
 32° Fahrenheit is equivalent to 0° Celsius
 $9/5^{\circ}\text{C} + 32 = ^{\circ}\text{F}$

APPROXIMATE CONVERSION FACTORS

TO CHANGE	TO	MULTIPLY BY
Inches	Centimeters	2.540
Feet	Meters	0.305
Yards	Meters	0.914
Miles	Kilometers	1.609
Square Inches	Square Centimeters	6.451
Square Feet	Square Meters	0.093
Square Yards	Square Meters	0.836
Square Miles	Square Kilometers	2.590
Acres	Square Hectometers	0.405
Cubic Feet	Cubic Meters	0.028
Cubic Yards	Cubic Meters	0.765
Fluid Ounces	Milliliters	29.573
its	Liters	0.473
arts	Liters	0.946
allons	Liters	3.785
Ounces	Grams	28.349
Pounds	Kilograms	0.454
Short Tons	Metric Tons	0.907
Pound-Feet	Newton-Meters	1.356
Pounds per Square Inch	Kilopascals	6.895
Miles per Gallon	Kilometers per Liter	0.425
Miles per Hour	Kilometers per Hour	1.609

TO CHANGE	TO	MULTIPLY BY
Centimeters	Inches	0.394
Meters	Feet	3.280
Meters	Yards	1.094
Kilometers	Miles	0.621
Square Centimeters	Square Inches	0.155
Square Meters	Square Feet	10.764
Square Meters	Square Yards	1.196
Square Kilometers	Square Miles	0.386
Square Hectometers	Acres	2.471
Cubic Meters	Cubic Feet	35.315
Cubic Meters	Cubic Yards	1.308
Milliliters	Fluid Ounces	0.034
Liters	Pints	2.113
Liters	Quarts	1.057
ers	Gallons	0.264
ms	Ounces	0.035
ograms	Pounds	2.205
Metric Tons	Short Tons	1.102
Newton-Meters	Pounds-Feet	0.738
Kilopascals	Pounds per Square Inch	0.145
ometers per Liter	Miles per Gallon	2.354
ometers per Hour	Miles per Hour	0.621



PIN: 017255-003